

Discussion Papers in Economics

VERTICAL DIVERSITY AND EQUILIBRIUM GROWTH

SATYA P. DAS

Discussion Paper 04-18

September 04



Indian Statistical Institute, Delhi
Planning Unit
7 S.J.S. Sansanwal Marg, New Delhi 110 016, India

VERTICAL DIVERSITY AND EQUILIBRIUM GROWTH*

SATYA P. DAS

Indian Statistical Institute, Delhi Centre

September 17, 2004

Abstract

This paper examines the effect of an increase in vertical diversity in workers' skill on the long run growth rate of an economy. It uses a two-sector model where the technology of the consumption-good sector is supermodular and that of the R&D sector is submodular. By adopting Grossman and Maggi's (2000) model to a framework of growth based on R&D, it shows first that diversity is conducive to growth. As the main innovation, communication gap is introduced among workers. It is then shown that growth may not be increasing with diversity. There may be an inverse-U shaped relationship.

Keywords: Diversity, Talent Distribution, supermodular technology, submodular technology, growth, skill, R&D, innovations

JEL Classification: J31, O2, O3,

Correspondence to:

Satya P. Das

Indian Statistical Institute – Delhi Centre

7 S.J.S. Sansanwal Marg

New Delhi 110016, India.

Tel: +91-11-2651-4594. Fax: +91-11-2685-6779

Email: das@isid.ac.in

*The idea behind the paper developed during the visit of Masahisa Fujita to Southern Methodist University. It has benefitted from presentations at University of California-Riverside, Emory University, Northern Illinois University, Pennsylvania State University, Southern Illinois University and Southern Methodist University.

1 Introduction

Diversity is a buzz word today. In attracting perspective students colleges and universities advertise the diversity in their student population. To attract businesses and professionals several cities pride themselves in diversity they offer. In the international context, for obvious reasons, there is an increasing realization to understand and appreciate diverse cultures. Specifically, economists have recently asked how ethnic diversity affects long-run growth of an economy. In their pioneering work Easterly and Levine (1997) have found that ethnic diversity has a negative impact on growth. Similar finding is reported by Zak and Knack (2001) for example. However, in the context of recent growth experience of various cities in the U.S., Florida (2002, 2004) have found that diversity in ethnic and in other dimensions promotes creativity and thereby enhances growth.¹

The diversity described above can be termed as *horizontal diversity* – referring to people with different cultures, ethnicity, religion etc. This paper, instead, is concerned with what can be called *vertical diversity* – more specifically, vertical diversity in the workers’ skill or talent – referring to the heterogeneity of the working population of a country in terms of ‘general’ education or skill. For instance, casual observation suggests that the working population in countries like Italy and U.S. is very heterogenous, compared to say Germany or Japan. Indeed, there are survey data available indicating significant differences across countries in the dispersion of skills. Table 1 shows the inequality of adult literacy across countries over 1994-98.

Country	Literacy: 9th Decile/1st Decile
U.S.A.	1.90
Canada	1.78
U. K.	1.75
Switzerland	1.72
Ireland	1.71
Australia	1.69
Belgium (Flanders)	1.68
Finland	1.54
Germany	1.51
Sweden	1.51
Netherlands	1.48
Norway	1.44
Denmark	1.39

Adapted from OECD Statistics of Canada (2000, Table 4.13)

Note that the ranking is consistent with Grossman and Maggi’s (2000, Table 1), whose data source is the same and which reports a subset of the countries listed here and provides summary statistics over 1994-95.²

The question posed in this paper is: How does vertical diversity in (intra-country) work-

¹In the backdrop of the lacklustre performance of the Japanese economy in the recent decade, several writers and long-run “vision” documents on Japan say that it is high time that basic creativity – rather than improvisation or innovation – must constitute the fundamental source of persistent growth, and for this to happen, the country must encourage diversity in terms of more liberal immigration policy. See, for example, Nippon Keidanren (2003).

²The indebtedness of the current paper to theirs will be apparent later.

ers' skill/talent affect long-run growth? If there are two countries and their average worker-skill (human capital) level is the same, then will the country with larger dispersion of skill achieve lower or higher long-run growth? Note that in addressing this issue, we completely abstract from the implications of human capital accumulation towards growth, on which a large and insightful literature exists (e.g. Lucas, 1988).

Our question begs another: What is the general process or mechanism through which vertical diversity may affect an economy's long-run growth? Let us view the economy as having two sectors: one producing a consumable and the other, an R&D sector, producing blueprints (ideas) *a la* Romer (1990). Let the technologies between the sectors be different so as to imply different structures of talent-matching. Further, let the dispersion of talents matter, especially in the production of the R&D sector which spells the growth rate.

More specifically let the consumption good be a manufacturing product, the technology of which is supermodular. This technology has the central feature that inputs (talents) are complementary to one another. If workers of varying talents are employed within a firm, in the extreme case, the performance of workers as a group is as good as that of the team's weakest link. A single mistake committed by any worker can jeopardise the entire output. There is a premium on precision. Kremer's (1993) O-ring technology is an example; see also Milgrom and Roberts (1990). Because of complementarity, in equilibrium there is "skill-clustering". A firm employs workers of same skill (but different firms may employ different levels of common skill). For a proof, see Kremer (1993) or Basu (1997). Skill-clustering and constant-returns together imply that the industry output is dependent only the total talent allocated to this sector, not its distribution.

Let the R&D sector be represented by submodular technology – which, in the extreme, means that performance is as good as that of the strongest link. The inputs are substitutes of each other. As an example, compared to a team with two average programmers, another having a better than average programmer and a less than average one, such that the average talent is same, fares better. Submodularity implies that efficiency is attained by cross-matching of skills. Because of cross-matching, the aggregate output depends on total talent available to this sector and its distribution.

In this scenario, a change in the diversity of worker skill will imply a change in the mix of talents allocated to production in the R&D sector, hence a change in output of the blueprints and thereby a change in the economy's growth rate.

At this point the reader may notice the closeness between the model economy just outlined and the model of 'diversity and trade' by Grossman and Maggi (2000), henceforth G-M. In the context of trade among similar countries, G-M have posed the following interesting puzzle: why do countries like Japan and Germany have comparative advantage in engineering goods (e.g. compact discs), whereas why do countries like US and Italy have comparative advantage in products like movies, software and designs? Their answer is that US and Italy have a more vertically diverse workforce than do Japan or Germany. What is the causal link? They view an economy as having two sectors: a supermodular sector and a submodular sector. It is argued that the supermodular sector produces engineering goods such as compact discs, which requires precision, whereas making of design, movies etc. is likely to be submodular, thriving on the performance of a very few highly talented workers. At any given level of diversity, the optimal allocation of talent between the two sectors is such that those whose talents are relatively close to the average are employed in the compact disc sector, whereas the design sector employs those whose talents are in the two tails of distribution, i.e. high

talents are matched with low. It then follows that if there is a mean-preserving spread in the distribution of talents, i.e., if the two tails become thicker, the (new) economy will produce relatively more of the designs. In the international trade context it means that if there are two countries between whom technologies and total talent available are the same but in one the talent distribution is more diverse than in the other, the former will have comparative advantage in the design sector.

One main innovation of this paper is to interpret G-M's supermodular 'compact disc sector' as the consumption-good sector, and, more particularly, their submodular 'design sector' as the R&D sector. This is only natural. As they note "... such a [submodularity] property may characterize some production processes, especially those requiring *creativity* or *problem solving*." "It is also true of many *research* activities, where an outstanding idea and some silly ones are worth more than a set of reasonable but not sterling suggestions." (Italics are added.)

In summary then vertical diversity affects growth through its effect on the matching of talents in the submodular R&D sector. This is somewhat related but quite different from the issue of allocation of talents examined by Murphy, Shleifer and Vishny (1991). In their model, a person's talent can be equally efficiently used in three different occupations: being a worker, an entrepreneur and a lobbyist. In the last two occupations there are increasing returns to talent. Therefore, in equilibrium, relatively high-talent individuals become entrepreneurs or lobbyists, whereas low-talent ones become workers. The effect of a change in the distribution of talents is not their focus however. A main point of theirs is that if a sufficiently large number of highly talented individuals choose to become lobbyists rather than entrepreneurs – and since lobbying is directly unproductive – it may be detrimental to an economy's growth.

We do not examine policies as such in our model. But it is important to keep in mind that the effect of horizontal diversity on growth has implications for policies with respect to immigration, discrimination etc., whereas that of vertical diversity on growth has implications largely for education policy: rigidity of the curriculum, the degree of emphasis on standardized test scores in the curriculum and in entry decision into schools and colleges, resources allocated to help top-end students to excel vis-a-vis resources for improving struggling students, emphasis on higher, professional-level education relative to primary education, etc.³ The implicit message is that not just the level of average education but the type of the education system matters for the growth of an economy.

2 Hypothesis of the Paper

Given our interpretation that the design sector of the G-M model is the R&D sector, their main result can be translated into saying that an increase in diversity increases the relative output of this sector. Indeed, we show that not only the relative output but also the *absolute* output of the R&D sector increases from a mean-preserving spread of talents. Thereby, an increase in vertical diversity enhances long-run growth. This is the starting hypothesis of our model.

The G-M model has the feature that very low talented workers can/do match with very high talented workers in the R&D sector. This is rather extreme. Although there may be substitutability among talents in this sector, a brilliant scientist or inventor may not be able to deliver much with a group of technicians with very low skills. It is natural to think that when the talent levels among workers differ greatly, they will have communication problems,

³Horizontal diversity can also be affected by selective immigration policy, e.g., whether to attract unskilled or skilled labor from abroad.

undermining output. The second – and the main – innovation of this paper is to introduce the notion of communication gap among workers: output is adversely affected when the talent difference among workers in a team is too large. Present such gaps, our model predicts that growth rate may not be monotonically increasing in vertical diversity. There may be an inverse-U shaped relation, as shown in Figure 1.

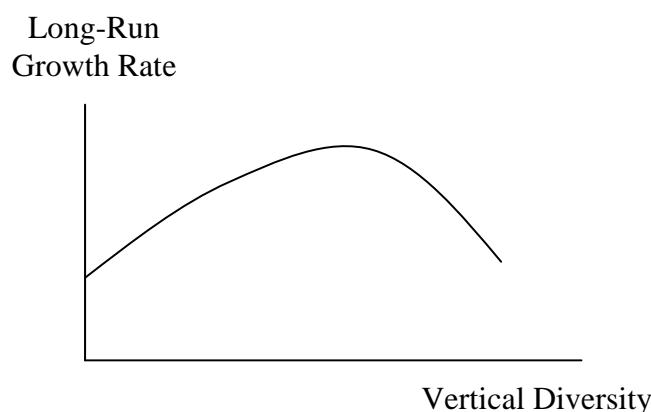

Figure 1: Vertical Diversity & Growth

This is the main hypothesis of this paper. Is it obvious? Suppose that communication gap is prohibitively large, i.e., two workers with *any* difference in talent cannot communicate at all and produce zero as a team. It then follows by assumption that talent clustering will also be the outcome in the R&D sector. Therefore the distribution of talents wouldn't matter: growth rate will be neutral with respect to diversity (the line in Figure 1 will be flat). What we show is that the inverse-U shape holds when the problem of communication is neither too severe nor too mild.⁴

In terms of international comparison, casual empiricism tells us that the education system is relatively flexible in the West (at least in the US) and rigid in the East (in countries like Japan and India). But, recently, we see a growing emphasis of standardized tests in the US and a more flexible curriculum system in countries like Japan and India. In other words, we may be witnessing a process of convergence. In view of Figure 1, it may be a good news!

In what follows, the basic model is introduced in section 3. Communication gap is analyzed in section 4. Income distributional implications of vertical diversity in the presence of communication gap are considered in section 5. Section 6 concludes the paper.

3 The Basic Model

It is a straightforward adaptation of the G-M model to a growth scenario.

3.1 The Static Model

A closed economy has two sectors/goods: a consumption-good sector C and an R&D sector S . There is one factor of production, labor. The total number of workers in the economy is

⁴If it is too mild, we are essentially in the G-M 'world' and the growth rate would monotonically increase with vertical diversity.

given, normalized to unity for notational ease. Each possesses one unit of labor, inelastically supplied to the market. Workers differ in their skill or talent (n), measured in some unidimensional unit along \bar{R}_+ . Its distribution is symmetric with $\Phi(n)$ as the cumulative density function and \bar{n} the mean.

A firm in either sector employs exactly two workers. Each is assigned to a task, A or B . Technology is linearly homogeneous and a symmetric function of tasks performed. Any worker can do either of the tasks. Let t_i denote talent allocated to task i . A firm's production function in sector C , $q^c = \mathcal{A}F^c(t_A^c, t_B^c)$, is supermodular. The critical feature of this technology is that the two tasks are complementary to each other: the cross partial F_{AB}^c is positive. Given constant-returns, each task is subject to diminishing returns. A standard CES function with convex isoquants is an example. Competitive production in this sector leads to talent clustering. In equilibrium each firm employs two workers of the same talent, but this common talent level can be different across firms. Hence the total output of good C (denoted Q^c) is proportional to the total talent allocated to this sector, independent of the distribution of talents working in this sector.

The R&D sector S produces \dot{A} (the time derivate of A), which embodies an improvement in technology for producing the consumption-good. These are the new blue-prints so-to-speak. As in Romer (1990), the level of existing technology or the stock of blueprints positively influences the output in sector S . In contrast to sector C , a firm's technology in sector S , $q^s = \mathcal{A}F^s(t_A^s, t_B^s)$, is submodular. Under this technology the tasks are substitutes, i.e., $F_{AB}^s < 0$. Constant returns to scale imply increasing returns to a task, i.e., $F_{AA}^s, F_{BB}^s > 0$. Also, (a) $F_B^s > F_A^s$ if and only if $\rho \equiv t_B/t_A > 1$. It can be further verified that (b) $F_{AA}^s + F_{BB}^s + 2F_{AB}^s > 0$, and if $\rho > 1$, (c) $dF_A^s/d\rho < 0 < dF_B^s/d\rho$ and (d) $d(F_A^s + F_B^s)/d\rho < 0$. The following is an example:

$$q^s = [(t_A^s)^\theta + (t_B^s)^\theta]^{1/\theta}, \quad \theta > 1. \quad (1)$$

It is CES only in appearance; given $\theta > 1$, own second derivatives are positive and the cross derivative is negative. In this sector, cross-matching of talents is the optimal choice by the firms. The total output depends on not just the total talent working in this sector but also on its distribution.

What is the allocation pattern of workers to the two sectors? A key result, due to Grossman and Maggi (2000), is that there exists a critical level of talent \tilde{n} ($< \bar{n}$) such that all workers in the talent range $(\tilde{n}, 2\bar{n} - \tilde{n})$ work in sector C and the rest in sector S . This is exhibited in Figure 2. The talents in the 'middle' of the distribution go to the supermodular sector and those in the two tails of the distribution work in the submodular sector. Furthermore, given symmetry of talent distribution, in sector S , a worker of talent n ($< \bar{n}$) is matched with a worker of skill $2\bar{n} - n$, i.e., the distance of talent n from the minimum talent is same as the distance of $2\bar{n} - n$ from the maximum talent.

Let L^c denote the total talent working in sector C . We have $L^c = \int_{\tilde{n}}^{2\bar{n}-\tilde{n}} n d\Phi(n) = \bar{n} [1 - 2\Phi(\tilde{n})]$. Normalizing $F^c(1, 1) = 1$, and recalling that a firm in either sector employs two workers,

$$Q^c = \mathcal{A}G^c, \quad \text{where } G^c = \frac{L^c}{2} = \bar{n} \left[\frac{1}{2} - \Phi(\tilde{n}) \right]. \quad (2)$$

Next, denoting the lowest talent by n_0 ,

$$Q^s = \dot{A} = \mathcal{A}G^s(\tilde{n}), \quad \text{where } G^s(\tilde{n}) \equiv \int_{n_0}^{\tilde{n}} F^s(n, 2\bar{n} - n) d\Phi(n). \quad (3)$$

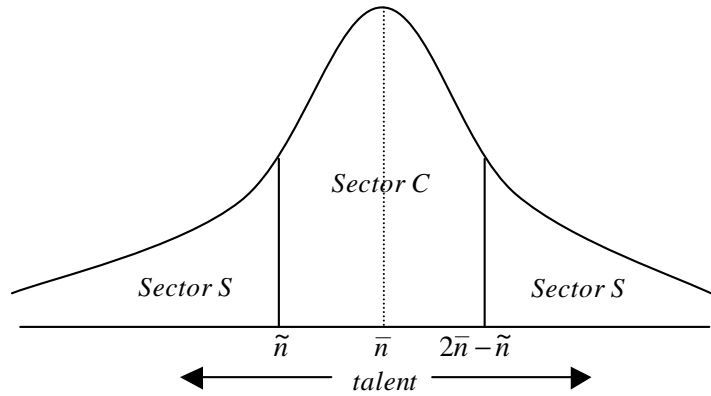

Figure 2: Allocation of Talents

For later purposes we interpret $G^s(\tilde{n})$ as the *TFP-adjusted output* in sector S , a function of total talent and the pattern of cross-matching in the sector.

The production possibility frontier in this economy is strictly concave, with its slope given by

$$-\frac{dQ^c}{dQ^s} = -\frac{dG^c/d\tilde{n}}{dG^s/d\tilde{n}} = \frac{\tilde{n}}{F^s(\tilde{n}, 2\bar{n} - \tilde{n})}. \quad (4)$$

This is equal to the competitive (relative) supply price of good S , say p_s . At any t the marginal talent \tilde{n} is determined by the market-clearing condition (to be specified).

For simplicity assume that there are no assets held by the private sector, and thus no private savings.⁵ Households spend all of their net income on good C . But there is a government which taxes all income proportionately (*a la* Barro, 1990). The tax proceeds are used to purchase the new blueprints \dot{A} in a competitive market. The government then freely offers these new blueprints (knowledge) to private producers in sector C . In other words, the knowledge-wealth is financed indirectly by the households via the government taxing the households. The tax rate, τ , is exogenous.

This is the simplest asset demand account in an economy one can think of, which helps to abstract from intertemporal decision making by households and thereby to focus on the problem of allocation of talents. The tax proceeds equal $\tau(Q^c + pQ^s)$. Thus $pQ^s = \tau(Q^c + pQ^s)$. Or,

$$p_d = \Lambda \frac{Q^c}{Q^s}, \quad \Lambda \equiv \frac{\tau}{1 - \tau} \quad (5)$$

where p_d is the demand price. Equating it to p_s in (4), and substituting the expressions of Q^c , Q^s , G^c and G^s , we obtain

$$\frac{1}{F^s(\tilde{n}, 2\bar{n} - \tilde{n})} = \Lambda \frac{1/2 - \Phi(\tilde{n})}{\int_{n_0}^{\tilde{n}} F^s(n, 2\bar{n} - n) d\Phi(n)}. \quad (6)$$

This is the market-clearing equation. It determines \tilde{n} and solves the model at any t . We see that \tilde{n} is time-invariant.

⁵This assumption is different from G-M's assumption on demand.

3.2 Growth

In this closed economy the amount consumed of good C is equal to its amount produced, whose expression is given in (2). Time-differentiating this and noting that \tilde{n} is independent of t , the growth rate of consumption equals $g = \dot{A}/A$. Since $Q^s = \dot{A}$, in view of (3), $\dot{A}/A = G^s(\tilde{n})$. Hence the economy's growth rate is equal to the TFC-adjusted output of the R&D sector:

$$g = G^s(\tilde{n}). \quad (7)$$

The solution of \tilde{n} solves the growth rate as well. There is no transitional dynamics.

3.3 Diversity and Growth

Let a mean-preserving spread of the talent distribution reflect an increase in vertical diversity. It will be modelled in an intuitive and simplest possible way. Fix the distribution $\Phi(n)$ and define talent as $\bar{n} + \gamma(n - \bar{n})$. It has mean \bar{n} for any value of γ . An increase in γ captures a mean-preserving spread.⁶

With such parametric specification, we have, however, the same expressions for G^c and hence the same expression for output in sector C as in (2).⁷ But, in sector S ,

$$G^s(\tilde{n}, \gamma) = \int_{n_0}^{\tilde{n}} F^s[\bar{n} - \gamma(\bar{n} - n), \bar{n} + \gamma(\bar{n} - n)] d\Phi(n). \quad (8)$$

Accordingly, the market-clearing eq. (6) can be rearranged to read as

$$\frac{\bar{n}}{F^s[\bar{n} - \gamma(\bar{n} - \tilde{n}), \bar{n} + \gamma(\bar{n} - \tilde{n})]} = \Lambda \frac{G^c(\tilde{n})}{G^s(\tilde{n}, \gamma)} \quad (9)$$

$$\Leftrightarrow \frac{1}{1/2 - \Phi(\tilde{n})} = \frac{F^s[\bar{n} - \gamma(\bar{n} - \tilde{n}), \bar{n} + \gamma(\bar{n} - \tilde{n})]}{\int_{n_0}^{\tilde{n}} F^s[\bar{n} - \gamma(\bar{n} - n), \bar{n} + \gamma(\bar{n} - n)] d\Phi(n)}. \quad (6')$$

In Appendix 1 it is proved that $d\tilde{n}/d\gamma < 0$. This implies that the total talent employed in and hence the (TFP-adjusted) output of sector C increases in γ . We have $dF^s/d\gamma = (F_B^s - F_A^s)(\bar{n} - \tilde{n} - \gamma d\tilde{n}/d\gamma) > 0$. Thus the l.h.s. of (9) falls, implying that the ratio G^c/G^s falls. Since G^c increases, G^s must increase. In other words, the TFP-adjusted outputs in both sectors expand. Given that sector S benefits from cross-matching, an increase in diversity, adding more of very high talents and very low talents to an economy is equivalent to a technological progress specific to sector S : the TFP-adjusted PPF shifts along the axis measuring good S .

The effects of an increase in diversity are illustrated in Figure 3. As $G^s(\cdot)$ increases, in view of (7), the economy's long-run growth is higher.

Proposition 1 *An increase in vertical diversity (without any communication gap) increases the growth rate of the economy.*

⁶A more general treatment is given in the G-M model.

⁷ $2G^c(\tilde{n}, \gamma)$

$$\begin{aligned} &= \int_{\tilde{n}}^{2\tilde{n}-\tilde{n}} [\bar{n} + \gamma(n - \bar{n})] \phi dn = (1 - \gamma)\bar{n}[\Phi(2\tilde{n} - \tilde{n}) - \Phi(\tilde{n})] + \gamma \int_{\tilde{n}}^{2\tilde{n}-\tilde{n}} n\phi(n) dn \\ &= (1 - \gamma)\bar{n}[\Phi(2\tilde{n} - \tilde{n}) - \Phi(\tilde{n})] + \gamma\bar{n}[\Phi(2\tilde{n} - \tilde{n}) - \Phi(\tilde{n})] \\ &= \bar{n}[\Phi(2\tilde{n} - \tilde{n}) - \Phi(\tilde{n})] = \bar{n}[1 - 2\Phi(\tilde{n})] \end{aligned}$$

Thus $G^c = \bar{n}[1/2 - \Phi(\tilde{n})]$.

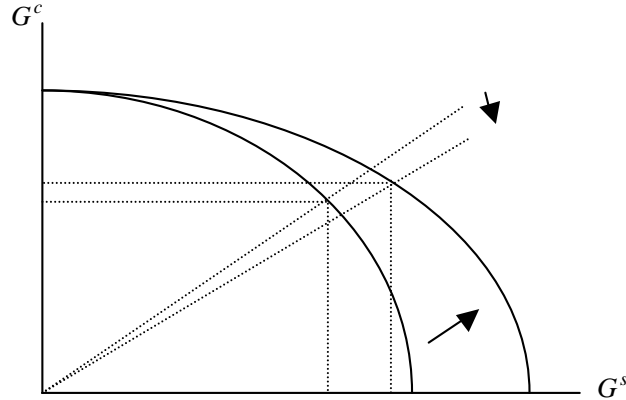

Figure 3: Diversity & PPF in the Basic Model

4 Communication Gap

At any given level of diversity, the presence of communication gap among workers implies a very different pattern of talent allocation between the two sectors from what is shown in Figure 2. The shape of the PPF is different. There is a richer set of possible equilibria along the PPF. An increase in diversity may impact differently on the shift of the PPF. Importantly, an increase in vertical diversity may not be equivalent to a sector-specific technological progress in the R&D sector. On one hand, the PPF tends to shift out as in case of no communication gap. But, on the other, the C.G. problems becomes increasingly binding. This gives rise to the possibility that the growth rate falls with diversity.

At a deeper level – yet in simpler terms – workers in the two tails of the talent distribution may not be matched, and, in particular, workers in the right-hand (high-talent) tail may not work in the R&D sector. Therefore, a mean-preserving spread of talents may not increase output in this sector.

For tractability we impose the following restrictions.

First, the talent distribution is uniform, having the support $\bar{n} \pm \beta$, where $\bar{n} > 0$ and $\beta \in [0, \bar{n}]$. The density is equal to $1/(2\beta)$. An increase in β captures an increase in vertical diversity. When $\beta = \bar{n}$, the lowest talent is zero and the talent diversity is the highest.

Second, communication gap holds in the simplest possible way. For some $k > 0$, two workers with a talent gap k or higher cannot communicate at all and output is zero if two such workers work together in a firm. If $k = 0$, the communication gap is prohibitive. We will presume that $k \in [2\bar{n}/3, \bar{n})$. That $k \leq \bar{n}$ means that in the case of highest diversity ($\beta = \bar{n}$), the most (or least) talented cannot communicate with anyone with below (or above) average talent. In this sense the communication gap is not too mild. The role of $k \geq 2\bar{n}/3$ will be clear later. For now it is sufficient to note that it represents not too severe communication gap.

Even with these assumptions the model is not fully amenable to analytical solution, but all of its major features are. In what follows, at most places, the phrase ‘communication gap’ will be abbreviated by C.G.

4.1 Various Ranges of Diversity

Given k , a natural classification of diversity, *relative to the communication gap*, emerges: low diversity: $\beta \leq k/2$, medium diversity: $\beta \in (k/2, k)$ and high diversity: $\beta \in [k, \bar{n}]$. This is shown in Figure 4. In the low diversity case, the talent difference between the most talented and the least talented, equal to 2β , doesn't exceed k . Hence C.G. does not bind for any pair of workers. Medium diversity case is the one where the most (least) talented can communicate with a proper subset of workers having less (more) than average talent. In the high diversity case, the most (least) talented cannot communicate with any one with less (higher) than average talent.

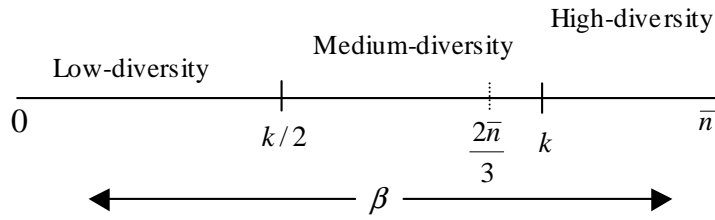

Figure 4: Degrees of Diversity

The last two cases are relevant for analysis.

4.2 Medium Diversity: $\beta \in (k/2, k)$

We first need to characterize the pattern of talent matching and talent allocation between the two sectors at any given level of diversity. For the sake of brevity, the term ‘output’ below will refer to TFP-adjusted output of a sector.

To begin with, suppose that all workers (talents) are used in sector S (although it will not be so in equilibrium). In the *absence* of C.G., talent $\bar{n} - \beta + \epsilon$ is matched with talent $\bar{n} + \beta - \epsilon$, for any $\epsilon \in [0, \beta]$. But C.G. affects the matching of talents at the two ends of the distribution: those in the ranges $(\bar{n} - \beta, \bar{n} + \beta - k)$ and $(\bar{n} - \beta + k, \bar{n} + \beta)$. Given that maximal cross-matching is the most efficient way of assigning talents, $\bar{n} - \beta + \epsilon$ will be matched with $\bar{n} - \beta + \epsilon + k$, for $0 \leq \epsilon \leq 2\beta - k$. Such matchings are shown by S2-S2 and the straightline arrows in Figure 5. The rest of the talents are not constrained by C.G.: the matchings between $\bar{n} - \beta + \epsilon$ and $\bar{n} + \beta - \epsilon$ continue to hold. These are shown by S1-S1, with bending arrows indicating the pairs.

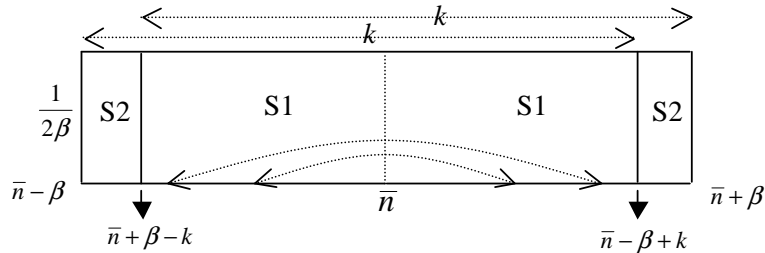

Figure 5: All Talents in Sector S

The patterns shown in Figure 5 facilitate the understanding of efficient talent allocation when there is some production of good C :

Proposition 2 *For any given level of diversity in the medium diversity range, the efficient talent allocation pattern is as shown in Figure 6.*

Proof: Consider panel (a). In view of Figure 5 it is clear that if a sufficiently small amount of good C is to be produced, the most efficient way is that it be produced by talents in a small neighborhood of \bar{n} (as in case of no C.G.). There is an intermediate range of high-talent and low-talent workers (shown by S1-S1 and bent arrows) who combine to produce good S and within whom there is no C.G. Finally, the rest of the workers in the two tails of talent distribution are constrained by C.G. These are S2-S2, as in Figure 5. Since the C.G. is binding for some workers in sector S , not all, we call this a case of communication gap being *partially binding*. Ignore for now the marking “Stage 1.”

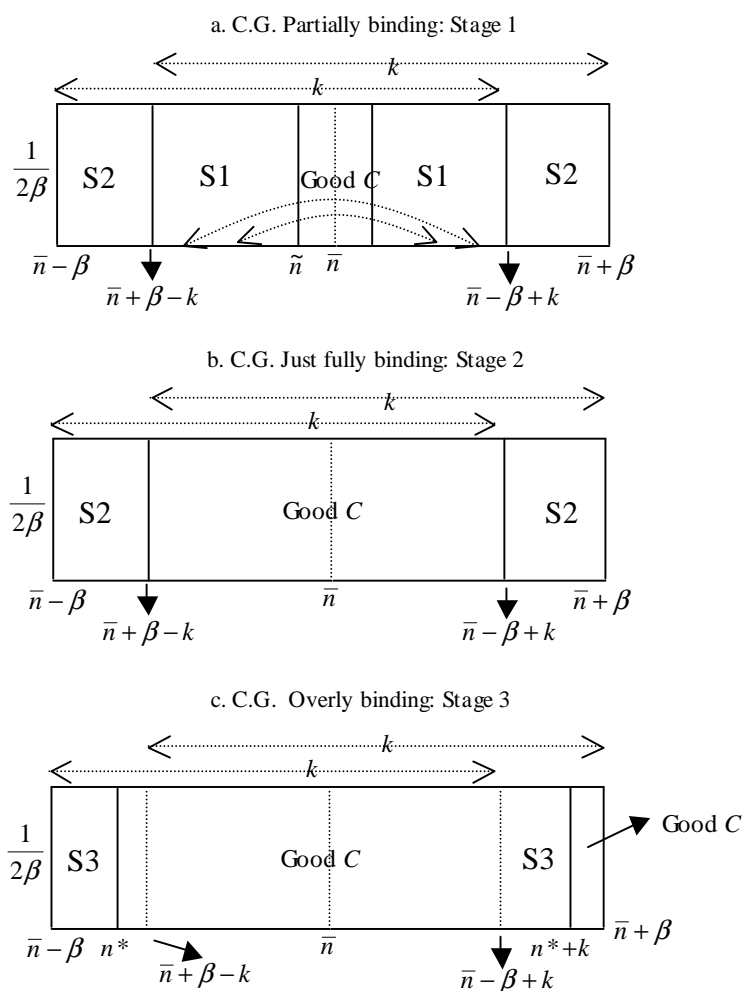

Figure 6: Talent Allocation in the Medium Diversity Range

As we consider gradually higher production of good C , less aggregate talent is available for sector S . This lowers the production of good S with areas S1-S1 in panel (a) gradually

shrinking. Panel (b) shows the critical level of total talent allotment between the two sectors such that the S1-S1 areas are zero. Communication gap is said to be *just fully binding* in sector S in the sense that sector S employs all pairs of workers in the economy between whom the talent difference is at least k and no other workers.

Finally, if more total talent is allocated to sector C , the production of good S has to be cut further. Some pairs of workers, between whom the talent difference is k , have to leave this sector. In this sense, communication gap can be said to be *more than fully binding*. Sector S can accommodate only a proper subset of workers with talent difference k or higher and no other workers. Which are these pairs? The following Lemmas lead to the answer.

Lemma 1: For any $c > 0$, $F^s(c - \alpha, c + \alpha)/c$ is a decreasing function in c . That is, the greater the average talent of two workers employed by a firm in sector S , the less is the *relative gain* in production from a *given* degree of cross-matching (i.e. given α).

Proof: Differentiation yields $d[F^s(c - \alpha, c + \alpha)/c]/dc = (1/c^2)[c(F_B^s - F_A^s) - F^s(c - \alpha, c + \alpha)] = (1/c^2)[c(F_B^s - F_A^s) - (c - \alpha)F_A^s - (c + \alpha)F_B^s] = -\alpha(F_B^s - F_A^s)/c^2 < 0$, since $c + \alpha > c - \alpha$ and thus $F_B^s > F_A^s$. \square

This means $F^s(c - \alpha, c + \alpha)/cF^s(1, 1) = F^s(c - \alpha, c + \alpha)/F^s(c, c)$ decreases with c . The last ratio is simply the ratio of output from cross-matching to that without any cross-matching. Lemma 1 is intuitive, because an increase in the average with a given α means less cross-matching relative to the average and hence less production gain relative to that when the same average talent is assigned to each task.

Lemma 2: Suppose all workers in the R&D sector S are constrained by C.G. The output of this sector is given by $R = \int_x^y F^s(n, n + k)d\Phi(n)$, for some x and y . Suppose further that the total availability of talent allocated to this sector is given, say equal to N_0 , i.e., $\int_x^y (n + n + k)\phi(n) \leq \bar{N}_0$. Then the output monotonically decreases with x .

Proof: The total talent availability constraint gives $y = y(x)$ with $dy/dx = \frac{(x+k/2)\phi(x)}{(y+k/2)\phi(y)}$. Using this and totally differentiating the expression of R ,

$$\begin{aligned} \frac{dR}{dx} &= \frac{(x + k/2)\phi(x)}{(y + k/2)\phi(y)} F^s(y, y + k)\phi(y) - F^s(x, x + k)\phi(x) \\ &= \left(x + \frac{k}{2}\right) \left[\frac{F^s(c' - k/2, c' + k/2)}{c'} - \frac{F^s(c - k/2, c + k/2)}{c} \right] \phi(x), \\ &\quad \text{where } c' \equiv y + k/2 > c \equiv x + k/2 \\ &< 0, \text{ by virtue of Lemma 1. } \quad \square \end{aligned}$$

Intuitively, on one hand, an increase in x tends to increase output, because higher talents than the earlier-best are now working. On the other, output produced by workers in the lower end and their partners is lost. Total talent being given, the increase in total talents used in the upper end must match the decrease in that in the lower end. Hence, whether the total output increases or decreases depends on the relative output gain from cross-matching in the two ends. The average talent in the upper end $(y + k/2)$ exceeds that in the lower end $(x + k/2)$. Lemma 1 then implies an output loss in the net as the lowest talent (x) is moved to the right.

Lemma 2 implies that if the output of good C is high enough, such that the pairs of workers with talent gap k or higher have to be rationed for work in sector S , the most efficient way of producing good S is to pair workers in the *lower* (left-hand) end of the talent range with those having higher talents by k units. Turning to panel (c) of Figure 6 it means that some workers to the immediate left of $\bar{n} + \beta - k$ and their partners in the very high-talent end now

work in sector C . In other words, interestingly, good C is produced by a range of workers whose talents are ‘around’ the average *as well as* by a range of most talented workers. Workers in S3-S3 are paired to serve in sector S .

This completes the proof of Proposition 2. ■

Proposition 2 implies the following expressions for sectoral outputs, ‘supply prices’ (slope of the PPF) and the market-clearing conditions.

Partially binding region: $\exists \tilde{n} > \bar{n} + \beta - k$ such that

$$G^c = \frac{\bar{n}(\bar{n} - \tilde{n})}{2\beta}; \quad G^s = \frac{1}{2\beta} \left[\int_{\bar{n}-\beta}^{\bar{n}+\beta-k} F^s(n, n+k)dn + \int_{\bar{n}+\beta-k}^{\tilde{n}} F^s(n, 2\bar{n} - n)dn \right] \quad (10)$$

$$p_s^p = -\frac{dG^c/d\tilde{n}}{dG^s/d\tilde{n}} = \frac{\bar{n}}{F^s(\tilde{n}, 2\bar{n} - \tilde{n})} \quad (11)$$

$$\frac{\bar{n}}{F^s(\tilde{n}, 2\bar{n} - \tilde{n})} = \Lambda \frac{G^c}{G^s} = \frac{\Lambda \bar{n}(\bar{n} - \tilde{n})}{\int_{\bar{n}-\beta}^{\bar{n}+\beta-k} F^s(n, n+k)dn + \int_{\bar{n}+\beta-k}^{\tilde{n}} F^s(n, 2\bar{n} - n)dn}. \quad (12)$$

Just fully binding point: $\tilde{n} = \bar{n} + \beta - k$, so that

$$G^c = \frac{\bar{n}(k - \beta)}{2\beta}; \quad G^s = \frac{1}{2\beta} \int_{\bar{n}-\beta}^{\bar{n}+\beta-k} F^s(n, n+k)dn. \quad (13)$$

Overly binding region: $\exists n^* \in (\bar{n} - \beta, \bar{n} + \beta - k)$, such that

$$G^c = \frac{1}{2\beta} \left[\bar{n}(k - \beta) + \int_{n^*}^{\bar{n}+\beta-k} \left(n + \frac{k}{2} \right) dn \right]; \quad G^s = \frac{1}{2\beta} \int_{\bar{n}-\beta}^{n^*} F^s(n, n+k)dn \quad (14)$$

$$p_s^o = -\frac{dG^c/dn^*}{dG^s/dn^*} = \frac{n^* + k/2}{F^s(n^*, n^* + k)} \quad (15)$$

$$\frac{n^* + k/2}{F(n^*, n^* + k)} = \Lambda \frac{\bar{n}(k - \beta) + (\bar{n} + \beta - k)(\bar{n} + \beta)/2 - n^*(n^* + k)/2}{\int_{\bar{n}-\beta}^{n^*} F^s(n, n+k)dn}. \quad (16)$$

Note that at the just fully binding point on the PPF, there is no unique supply price: it is bound within p_s^p and p_s^o , evaluated $\tilde{n} = n^* = \check{n}$, where $\check{n} \equiv \bar{n} + \beta - k$. We can check that $p_s^p|_{\tilde{n}=\check{n}} > p_s^o|_{n^*=\check{n}}$.⁸

The output expressions imply that the PPF looks like the one in in Figure 7. When the output of sector C is small or large enough, sector S is respectively partially or overly constrained by C.G. Inbetween, there is a kink where C.G. just fully binds.⁹

⁸ $p_s^p|_{\tilde{n}=\check{n}} > p_s^o|_{n^*=\check{n}}$ is equivalent to

$$\frac{F^s(\bar{n} + \beta - k, \bar{n} + \beta)}{\bar{n} + \beta - k/2} > \frac{F^s(\bar{n} + \beta - k, \bar{n} - \beta + k)}{\bar{n}} \Leftrightarrow \frac{F^s(\check{n}, \check{n} + k)}{\check{n} + k/2} > \frac{F^s(\check{n}, \check{n} + 2v)}{\check{n} + v},$$

where $v \equiv k - \beta$. Given $k/2 > v$, it is sufficient to show that $\partial \frac{F^s(x, x+2y)}{x+y} / \partial y > 0$, when $2y > x$. Check that the partial is equal to $\frac{x(F_B^s - F_A^s)}{(x+y)^2} > 0$.

⁹That is, there is a discrete increase in the marginal opportunity cost of producing good S . Intuitively, any expansion of output in the overly binding range occurs when there is relatively high cross-matching of talents (with talent difference, k), whereas in the partially binding range the degree of cross-matching is less. Since submodular technology rewards greater cross-matching, a unit increase in the output of good S entails less increase in total talent in that sector in the overly binding range than in the partially binding range.

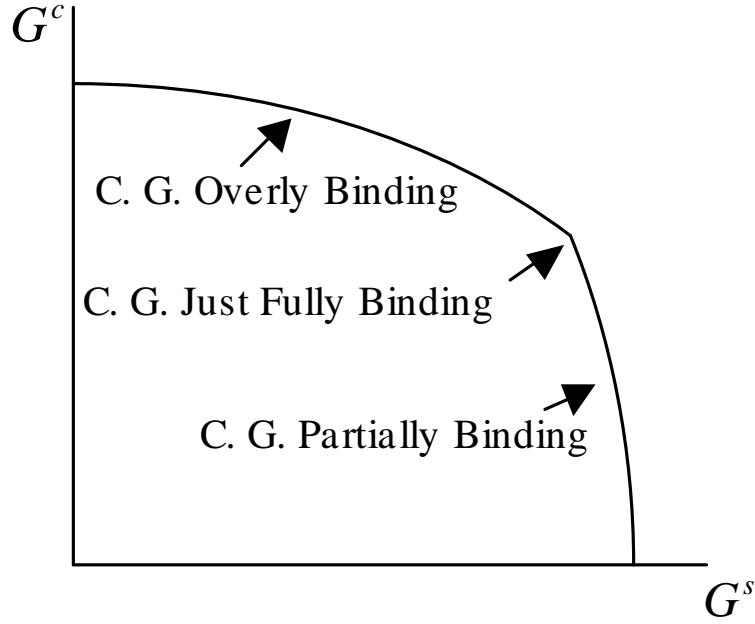

Figure 7: Production Possibility Frontier: Medium Diversity

4.2.1 Increase in Diversity

As in the basic model the equilibrium growth rate is equal to the (TFP-adjusted) output of sector S . The issue is how an increase in β affects the PPF, its shift and the equilibrium output in sector S , G^s .

We begin to understand this by asking how the maximum G^s (when all workers are employed in sector S) changes with β . As proven in Appendix 2 it increases with β . Thus the PPF shifts to the right on the G^s -axis. Therefore, the equivalence between an increase in vertical diversity and a sector-specific technical progress in sector S holds. This would indicate that an increase in diversity would raise the (TFP-adjusted) output in sector S and thus enhance the growth rate.

We can derive from (13) that G^c and G^s at the just fully binding point respectively fall and rise with β .¹⁰ Thus, as β increases, the kink moves down and to the right. Finally, at $\beta = k$, the partially binding region disappears. Such shifts are shown in Figure 8.

We now characterize the effect of an increase in β in each region.

If $\beta - k/2$ is small enough, it is clear that the equilibrium must lie in the partially-binding region, to the right of the kink on the PPF. We call this Stage 1. Comparative statics of the

¹⁰It is obvious that $dG^c/d\beta < 0$. Next, note that $\int_{\bar{n}-\beta}^{\bar{n}+\beta-k} F^s(n, n+k)dn < F^s(\bar{n} + \beta - k, \bar{n} + \beta) \int_{\bar{n}-\beta}^{\bar{n}+\beta-k} dn = (2\beta - k)F^s(\bar{n} + \beta - k, \bar{n} + \beta)$. Now from (13),

$$\begin{aligned} 2\beta^2 \frac{dG^s}{d\beta} &= \beta[F^s(\bar{n} + \beta - k, \bar{n} + \beta) + F^s(\bar{n} - \beta, \bar{n} - \beta + k)] - \int_{\bar{n}-\beta}^{\bar{n}+\beta-k} F^s(n, n+k)dn \\ &> \beta[F^s(\bar{n} + \beta - k, \bar{n} + \beta) + F^s(\bar{n} - \beta, \bar{n} - \beta + k)] - (2\beta - k)F^s(\bar{n} + \beta - k, \bar{n} + \beta) \\ &= (k - \beta)F^s(\bar{n} + \beta - k, \bar{n} + \beta) + \beta F^s(\bar{n} - \beta, \bar{n} - \beta + k) > 0. \end{aligned}$$

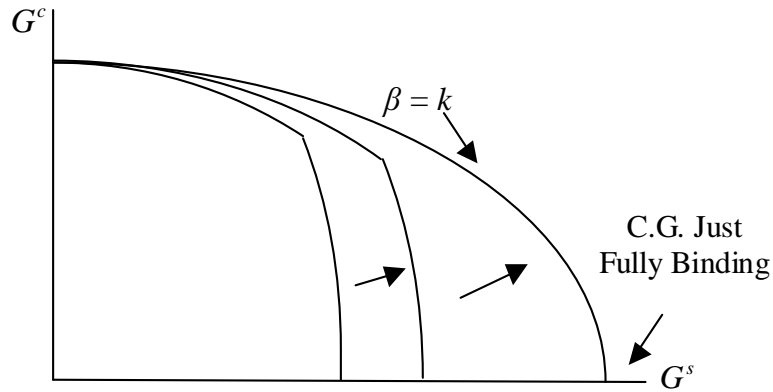

Figure 8: Shifts of the PPF in the Medium Diversity Case as β increases

market-clearing condition (12) gives $d\bar{n}/d\beta < 0$, and, $d(G^c/G^s)/d\beta > 0$. These results are same as in the G-M model. How does the growth rate change with β ? It is proven in Appendix 3 that $dG^s/d\beta > 0$, i.e. the growth rate increases with diversity.

As $\beta \rightarrow k$, G^s in (10) becomes negative, which is impossible. It then follows that, at some $\beta (< k)$, say β_1 , the economy 'enters' the just-fully binding point, say stage 2.¹¹ In Appendix 4, it is shown that β_1 is the solution to the following equation in β :

$$\frac{1}{F^s(\bar{n} + \beta - k, \bar{n} - \beta + k)} = \frac{\Lambda(k - \beta)}{\int_{\bar{n}-\beta}^{\bar{n}+\beta-k} F^s(n, n+k)dn}.^{12} \quad (17)$$

In stage 2 also, $dG^s/d\beta > 0$; see footnote 10.

When $|\beta - k|$ is small enough, the economy's equilibrium must shift to the overly binding region before β assumes the value k . Because, if not, from (13), $Q^c = 0$ at $\beta = k$, which is not possible. We then call this Stage 3. Let β_2 denote the critical β separating stage 2 and stage 3. As shown in Appendix 4 also, it is the solution to the equation:

$$\frac{1 + (\beta - k/2)/\bar{n}}{F^s(\bar{n} + \beta - k, \bar{n} + \beta)} = \frac{\Lambda(k - \beta)}{\int_{\bar{n}-\beta}^{\bar{n}+\beta-k} F^s(n, n+k)dn}. \quad (18)$$

Full analytical characterization of stage 3 does not seem possible however. From the market-clearing condition given in (16), $dn^*/d\beta \geq 0$.¹³ It is also hard to determine the sign of $dG^s/d\beta$ in general. However, simulations were carried out assuming (1) as the production function in sector S . There are essentially three parameters, Λ (the demand parameter), β and k .¹⁴ For all ranges of permissible parameter values, it turned out that $dG^s/d\beta > 0$. In any event, the following proposition holds:

¹¹ Although G^c/G^s ratio falls, the kink falls faster such that entering this region is inevitable.

¹² A solution to β in $(k/2, k)$ always exists and it is unique, since the l.h.s. is positive, finite and increasing in β , where the r.h.s. decreases with β and tends to ∞ or 0 as $\beta \rightarrow k/2$ or k .

¹³ But it can be derived that $dn^*/d\beta < 1$, implying that, as β increase, n^* does not exceed or become equal to $\bar{n} + \beta - k$. That is, a reversal of stage 3 to stage 2 cannot occur.

¹⁴ Given constant returns, we can normalize \bar{n} to one.

Proposition 3 *Within the medium-diversity range, an increase in diversity is associated with an increase in the growth rate in stages 1 and 2.*

4.3 High Diversity: $\beta > k$

This is where an increase in vertical diversity can hurt the growth rate. We first characterize the patterns of talent allocation, which are quite different from the medium-diversity case. It will be handy to begin with the situation where there is no production of good C .

Lemma 3: Given $\beta > k$, if all talents are used in sector S , then talent $n \in (\bar{n} - \beta, \bar{n} - \beta + k)$ is matched with talent $n + k \in (\bar{n} - \beta + k, \bar{n} - \beta + 2k)$, i.e., C. G. is binding for workers in these two ranges of talent. It is not binding for the rest: talent $n \in (\bar{n} - \beta + 2k, \frac{\bar{n}+k}{2})$ is matched with talent $2(\bar{n} + k) - n \in (\frac{\bar{n}+k}{2}, \bar{n} + k)$.¹⁵

This lemma essentially says that the efficient allocation dictates that workers at the high-end of talent distribution be *not* constrained, i.e., they be paired with less talented workers with a talent gap smaller than k , and, workers in the lower-end of the talent distribution be constrained – matched with workers whose talents are exactly k units higher.

Graphically, in Figure 15 in the Appendices, the point $b - 2k$ coincides with n_0 . Together with Lemma 2, Lemma 3 implies

Proposition 4 *In the range of high-diversity, the talent allocation patterns are as shown in Figure 9.*

Lemma 2 is the key behind Lemma 3 and Proposition 4: The less the average talent of two workers, the greater is the output gain from cross-matching under submodular technology. Starting from no production of good C , if there is some production of this good, some of the workers in sector S for whom C.G. is not binding now work in sector C . As the output of sector C further expands, the just fully binding point on the PPF is reached. There is a simple but interesting partition of sectoral talent allocation in this case: There exists a critical talent $(\bar{n} - \beta + 2k)$ such that all talent below (above) it work in sector S (C). In keeping with Lemma 2, further expansion of good C is best accomplished by reallocating the ‘relatively’ high-end workers and their partners in sector S to sector C .

Figure 9 leads to the following output and supply price expressions and the market-clearing conditions.

Partially binding: $\exists \tilde{n} > \bar{n} - \beta + 2k$ such that

$$\begin{aligned} G^C &= \frac{1}{2\beta} \int_{\tilde{n}}^{2\tilde{n}+2k-\tilde{n}} \frac{n}{2} dn \\ G^S &= \frac{1}{2\beta} \left[\int_{\tilde{n}-\beta}^{\tilde{n}-\beta+k} F^S(n, n+k) dn + \int_{\tilde{n}-\beta+2k}^{\tilde{n}} F^S(n, 2\tilde{n}+2k-n) dn \right] \end{aligned} \quad (19)$$

$$p_s^p = \frac{\bar{n} + k}{F^S(\tilde{n}, 2\tilde{n} + 2k - \tilde{n})} \quad (20)$$

$$\frac{\bar{n} + k}{F^S(\tilde{n}, 2\tilde{n} + 2k - \tilde{n})} = \Lambda \frac{(\bar{n} + k)(\bar{n} + k - \tilde{n})}{\int_{\tilde{n}-\beta}^{\tilde{n}-\beta+k} F^S(n, n+k) dn + \int_{\tilde{n}-\beta+2k}^{\tilde{n}} F^S(n, 2\tilde{n} + 2k - n) dn} \quad (21)$$

Just Fully binding: Here $\tilde{n} = \bar{n} - \beta + 2k$. Thus

$$G^C = \frac{1}{2\beta} \int_{\bar{n}-\beta+2k}^{\bar{n}+\beta} \frac{n}{2} dn; \quad G^S = \frac{1}{2\beta} \int_{\bar{n}-\beta}^{\bar{n}-\beta+k} F^S(n, n+k) dn. \quad (22)$$

¹⁵The proof is given in Appendix 5. Our assumption $k > 2\bar{n}/3$ plays a role in this result. That is, there are only two “batches” (intervals) of workers who are matched with one from each batch and for whom the C.G. is binding. In other words, the difference between the talents $\bar{n} + \beta$ and $\bar{n} - \beta + 2k$ equals $2\beta - 2k$ which is less than k as long as $k > 2\bar{n}/3$.

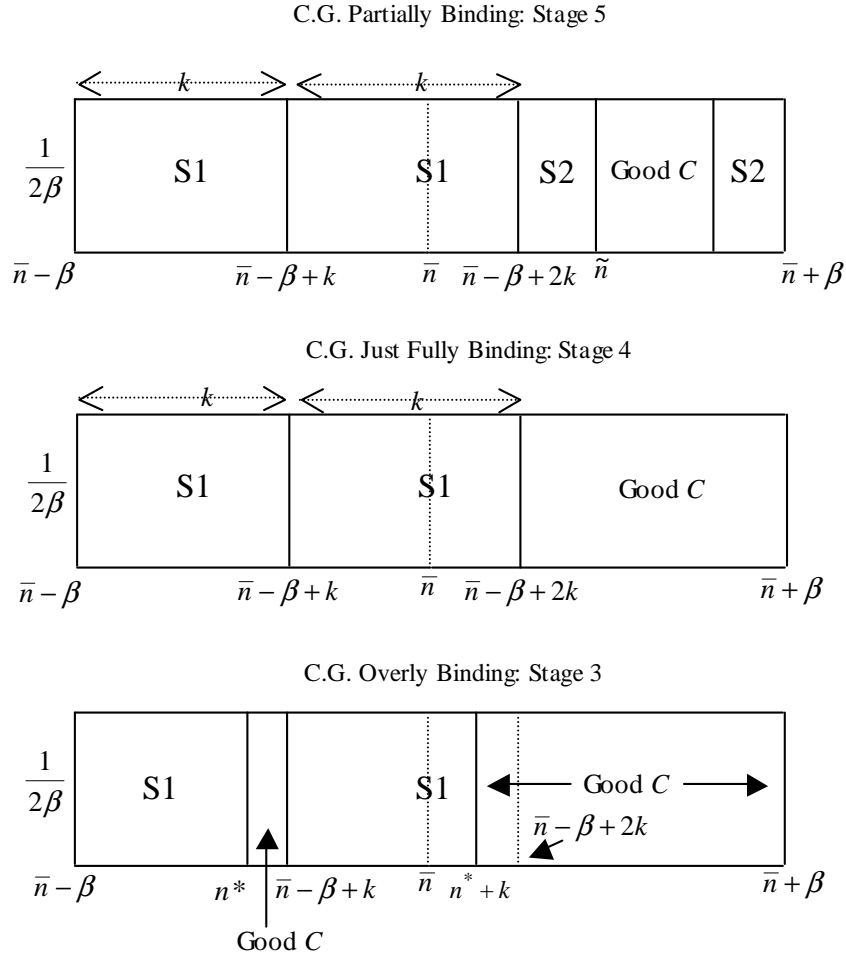

Figure 9: Talent Allocation in the case of High Diversity

Overly binding: $\exists n^* < \bar{n} - \beta + k$, such that

$$G^c = \frac{1}{2\beta} \left(\int_{n^*}^{\bar{n} - \beta + k} \frac{n}{2} dn + \int_{n^* + k}^{\bar{n} + \beta} \frac{n}{2} dn \right); \quad G^s = \frac{1}{2\beta} \int_{\bar{n} - \beta}^{n^*} F^s(n, n + k) dn \quad (23)$$

$$p_s^o = \frac{n^* + k/2}{F^s(n^*, n^* + k)} \quad (24)$$

$$\frac{n^* + k/2}{F^s(n^*, n^* + k)} = \Lambda \frac{\int_{n^*}^{\bar{n} - \beta + k} \frac{n}{2} dn + \int_{n^* + k}^{\bar{n} + \beta} \frac{n}{2} dn}{\int_{\bar{n} - \beta}^{n^*} F^s(n, n + k) dn}. \quad (25)$$

Similar to the case of medium diversity, the PPF has a kink at the just-fully-binding point, i.e. $p_s^p > p_k^o$ (proven in Appendix 6). Figure 10 illustrates the PPF. The pattern of shifts in the PPF as β changes is however different.

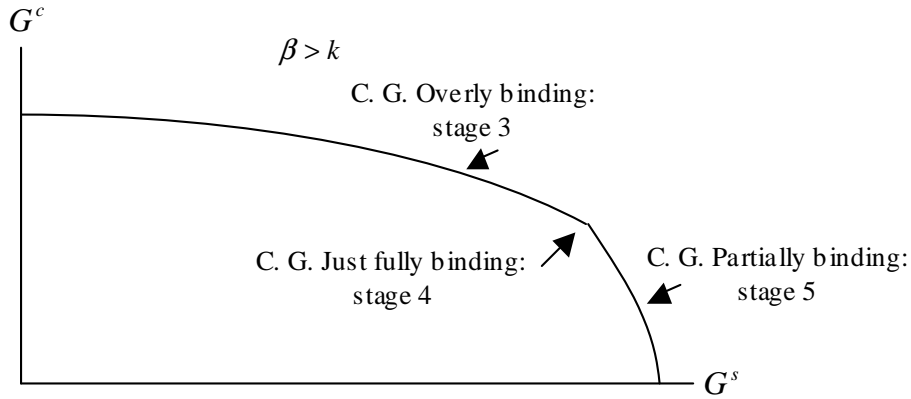

Figure 10: Production Possibility Frontier when there is High Diversity

Increase in Diversity

We have already seen that near the end of medium diversity the economy operates in Stage 3 (the overly binding region). As β begins to ‘cross’ k , to which region in the high-diversity range does the economy move to? Note from Figures 6 and 9 that, at $\beta = k$, the overly binding regions in both medium-diversity and high-diversity situations collapse to one. Hence this region is the only possibility. We continue to call this Stage 3.

Interestingly, starting with the overly binding region, the economy may move to the just-binding point and then to the partially binding region – exactly the reverse of what happens in the medium-diversity case. The reason behind this will be seen later. For now, as β increases continuously and approaches \bar{n} , there are three possibilities. The economy (i) stays in stage 3 throughout, (ii) moves to and stay in the just fully-binding point, Stage 4, for higher values of β or (iii) it moves first to Stage 4 and then from Stage 4 to the partially binding region, Stage 5. Which one holds depends on the demand parameter Λ :

Proposition 5 *Let*

$$\Lambda_1 \equiv \frac{3 \int_0^k F^s(n, n+k) dn}{2(\bar{n}^2 - k^2)F^s(1, 2)}; \quad \Lambda_2 \equiv \frac{\int_0^k F^s(n, n+k) dn}{2(\bar{n} - k)F^s(k, \bar{n})}.$$

Note that $\Lambda_1 < \Lambda_2$. The economy stays in stage 3 for all $\beta \in [k, \bar{n}]$ if $\Lambda \leq \Lambda_1$. If $\Lambda \in (\Lambda_1, \Lambda_2)$, there exists a critical value of $\beta \in (k, \bar{n})$ such that for all β less than or equal to this critical value, the economy operates in stage 3 and for β higher, the economy operates in stage 4. Finally, if $\Lambda > \Lambda_2$, there exist two critical values of β , say, β_3 and β_4 , with $k < \beta_3 < \beta_4 < \bar{n}$, such that the economy’s equilibrium is respectively in stage 3, stage 4 and stage 5 as $\beta \in (k, \beta_3]$, $\beta \in (\beta_3, \beta_4)$ and $\beta \in [\beta_4, \bar{n}]$.

Proof: Evaluate the supply price in the overly binding region, p_s^o , at $n^* = \bar{n} - \beta + k$. Equate it to $\Lambda G^c/G^s$, where G^c and G^s are the respective expressions at the *just fully binding point*, i.e.,

$$\frac{\bar{n} - \beta + 3k/2}{F^s(\bar{n} - \beta + k, \bar{n} - \beta + 2k)} = \Lambda \frac{(\bar{n} + k)(\beta - k)}{\int_{\bar{n}-\beta}^k F^s(n, n+k) dn}. \quad (26)$$

View this as an equation in β . If there exists $\beta \in (k, \bar{n})$, which solves the above equation, then the economy must enter stage 4 at that value of β . The l.h.s. of (26) is decreasing and the r.h.s.

is increasing in β . Further, at $\beta = k$, the l.h.s. is positive, whereas the r.h.s. = 0. Hence the condition required for the existence of such a β is that the r.h.s. \geq l.h.s. at $\beta = \bar{n}$. This is equivalent to

$$\Lambda \frac{\bar{n}^2 - k^2}{\int_0^k F^s(n, n+k)dn} \geq \frac{3}{2F^s(1,2)} \Leftrightarrow \Lambda \geq \frac{3 \int_0^k F^s(n, n+k)dn}{2(\bar{n}^2 - k^2)F^s(1,2)}.$$

The r.h.s. of the last inequality is same as Λ_1 . Hence, as long as $\Lambda > \Lambda_1$, there must exist some $\beta \in (k, \bar{n})$ beyond which there is a range of β such that the economy operates in stage 4. The solution of β from (26) defines β_3 .

Analogous reasoning applied to the market-clearing equation in the partially binding region gives the following analog of (26).

$$\frac{\bar{n} + k}{F^s(\bar{n} - \beta + 2k, \bar{n} + k)} = \Lambda \frac{(\bar{n} + k)(\beta - k)}{\int_{\bar{n}-\beta}^{\bar{n}-\beta+k} F^s(n, n+k)dn}. \quad (27)$$

Substituting $\beta = \bar{n}$ yields $\Lambda = \Lambda_2$. If $\Lambda > \Lambda_2$, there must exist β beyond which the equilibrium lies in the partially binding region only; this is the solution to the eq. (27), defining β_4 . ■

Intuitively, how equilibrium moves from one region to another as β increases depends on how the kink on the PPF shifts. Note from Figure 9 that, at the kink (the just fully binding point), high-talent-end workers work in sector C and the rest in sector S and therefore an increase in β increases the production of good C and lowers the production of sector S (verifiable from (22)). Hence, as β increases, the kink moves up and to the left. As a result, the scope of equilibria on as well as to the right of the kink occurring in sequence increases. This explains the transition of the equilibrium from the overly binding to the just binding region and that from the just binding to the partially binding region.

How does the PPF shift? As discussed above the kink on it moves up and to the left. Importantly, does the maximal output on the G^s -axis increases with β ? It is proven in Appendix 7, it may not. It is because *workers in the two tails of the distribution are not matched, and, more specifically, workers in the high-end of talent distribution do not work in the R&D sector, while those in the low-end do*. This is indeed the key. An increase in vertical diversity is no more equivalent to a sector-specific technical progress. It is quite plausible that higher diversity reduces economic growth.¹⁶

We now characterize equilibrium in each stage individually. As in the medium-diversity case, in stage 3, $dn^*/d\beta \geq 0$ and it is hard to sign $dG^s/d\beta$.¹⁷

Assume that $\Lambda > \Lambda_1$, such that for some range of β , the economy operates in stage 4. In this stage, a simple comparative statics yields $dG^s/d\beta = \beta[-F^s(\bar{n} - \beta + k, \bar{n} - \beta + 2k) + F^s(\bar{n} - \beta, \bar{n} - \beta + k)] - \int_{\bar{n}-\beta}^{\bar{n}-\beta+k} F^s(n, n+k)dn / (2\beta^2) < 0$. That is, the growth rate falls with higher diversity.

¹⁶Indeed, we can simply observe and determine from (22) that as β increases and the equilibrium continues to be at the fully-binding point, the growth rate falls unambiguously.

¹⁷The market-clearing equation (25) determines n^* . Totally differentiating it,

$$\frac{dn^*}{d\beta} = \frac{\Lambda(\beta - k/2)F^s(n^*, n^* + k) - (n^* + k/2)F^s(\bar{n} - \beta, \bar{n} - \beta + k)}{\left[1 - \frac{(n^* + k/2)(F_A^s + F_B^s)(n^*, n^* + k)}{F^s(n^*, n^* + k)}\right] \int_{\bar{n}-\beta}^{n^*} F^s(n, n+k)dn + (1 + \Lambda)(n^* + k/2)F^s(n^*, n^* + k)} \geq 0,$$

as the denominator is positive but the numerator is ambiguous in sign. Even though n^* may fall, it is easy to check that $1 + dn^*/d\beta > 0$, that is, the gap between $\bar{n} - \beta + k$ and n^* narrows as β increases. This indicates that for higher values of β , stage 4 is the only other possibility.

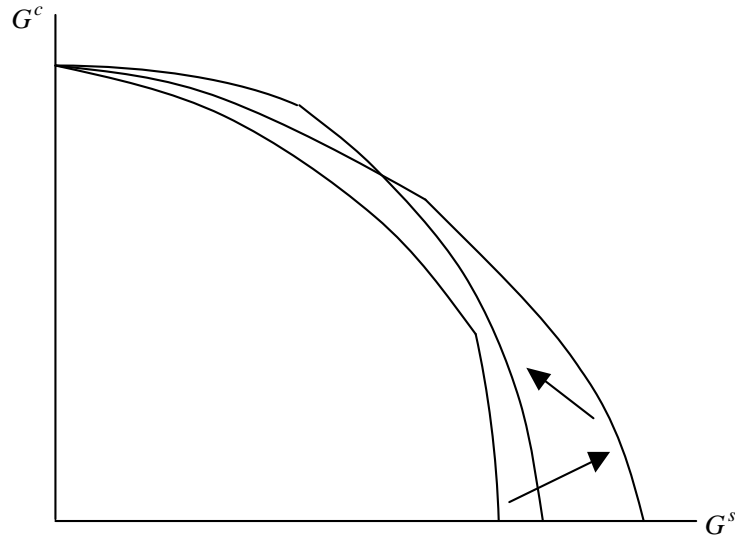

Figure 11: PPF Shifts in the High-Diversity Range as β increases

Now suppose $\Lambda > \Lambda_2$ and $\beta > \beta_4$. The economy operates in stage 5. We can inspect from the market-clearly equation (21) that $d\bar{n}/d\beta < 0$ and $d(G^c/G^s)/d\beta < 0$. Importantly, in this range the growth rate may decline with β also. As a sufficient condition, as proven in Appendix 8, if the PPF shifts to the left on the G^s -axis, $dG^s/d\beta < 0$ in Stage 5.

In summary, the following overall pattern emerges:

Proposition 6 *If $\Lambda \in [\Lambda_1, \Lambda_2]$, stage 4 is the ‘terminal’ stage and within this stage the growth rate decreases with diversity. If $\Lambda \geq \Lambda_2$, stage 5 is the terminal stage. In stage 4, growth declines with diversity and the same holds in stage 5 if the PPF shifts to the left on G^s -axis.*

The upshot is that in the presence of communication gap, beyond a critical level of diversity, the growth rate may decrease with diversity. In what follows, this is illustrated through a numerical example.

4.3.1 An Example

Normalize $\bar{n} = 1$. Choose $k = 0.75$ and $\theta = 5$. This gives $\Lambda_2 = 4.86$. Select $\Lambda = 3\Lambda_2 = 14.58$. The choice of Λ_2 amply ensures that, as β increases from k , this economy must pass through stages 1-5. We have $\beta_1 = 0.628$, $\beta_2 = 0.636$, $\beta_3 = 0.837$ and $\beta_4 = 0.848$. Figure 12 depicts the resulting “diversity-growth” curve.

Note that the purpose of this example is to illustrate only the *possibility* of the inverse-U shape relationship between vertical diversity and the growth rate. It is not to calibrate an economy with ‘realistic’ parameters and variable-solutions; this will necessitate various adjustments and extensions. For instance, the growth rate in the example moves in the 50 to 60% range. But this is a matter of unit. Redefine the technology in the R&D sector as $Q^s = \mathcal{A} = \mathcal{A}\eta F^s(\cdot)$, where η is a technology constant that doesn’t change with R&D. It does not affect the analysis at all, but changes the growth rate by a multiple of η . If, for instance, we choose $\eta = 0.1$, the range of the growth rate is now 5-6%. Also, $\Lambda = 14.58$ implies a

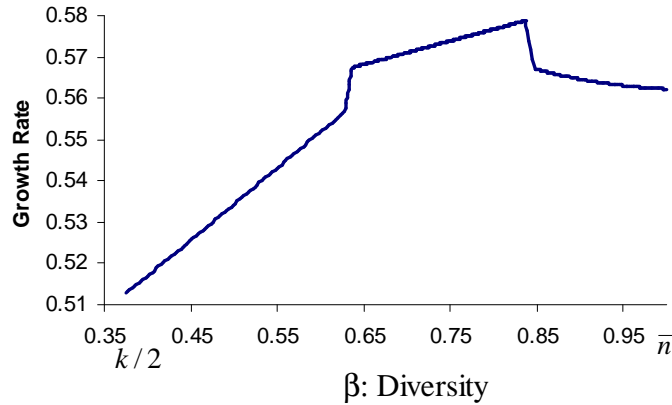

Figure 12: Diversity & Growth: An Example

savings rate (same as the tax rate), equal to 93%. However, if we allow, for instance, another consumable sector, which is produced by some other inputs whose endowment is fixed (e.g. land, natural resources or labor in a region from which migration to other regions/sectors is negligible), then the total tax base will be higher. Assume that this sector benefits from R&D as well. Denoting this sector's TFP-adjusted output as V , from the market-clearing condition, the relative demand price of the R&D sector is then $\Lambda(G^c + V)$. Higher V , the lower will be the required value of Λ for which the economy will pass through stages 1-5.

5 Income Distribution

Income distribution is a derivative of vertical diversity. There are two questions here. What is the pattern of wage distribution at any given level of diversity? How does this pattern change as diversity increases and the economy passes through the various stages?

The level of diversity given, in the steady state all workers experience wage growth equal to the growth rate of the economy. In looking into the pattern of distribution we can thus suppress the growth aspect. In sector C , the zero-profit condition gives $2w(n) = \mathcal{A}n \Rightarrow w(n) = \mathcal{A}n/2$, where recall that we have used the normalization $F^c(1, 1) = 1$. Thus wages increase linearly with talent employed in this sector.

In sector S , as shown by G-M, if the high- (low-) talent is assigned the task B (A), then wage to the low-talent worker is such that $dw/dn \equiv w'(n) = F_A^s$ and that to the high-talent worker is such that $w'(n) = F_B^s$. Their model further implies that in the absence of communication gap, $w''(n) > 0$, that is wage function is convex for workers in both ends. This is because an increase in talent in the high-talent end would increase the ratio of high-talent to low-talent and this would increase the marginal product of talent (in the high-talent end). In the low-talent end, an increase in talent would reduce the ratio of high-talent to low-talent, which would also increase the marginal product of talent in the low-talent end.¹⁸

Compared to the absence of C.G., in the presence of C.G., there is no change in the pattern of wage distribution in sector C , and no change in sector S as long as C.G. doesn't bind. But,

¹⁸Algebraically, $w''(n) = dF_A^s(\cdot)/dn = F_{AA}^s - F_{AB}^s > 0$ and $w''(n)|_{2\bar{n}-n} = F_{BB}^s - F_{AB}^s > 0$.

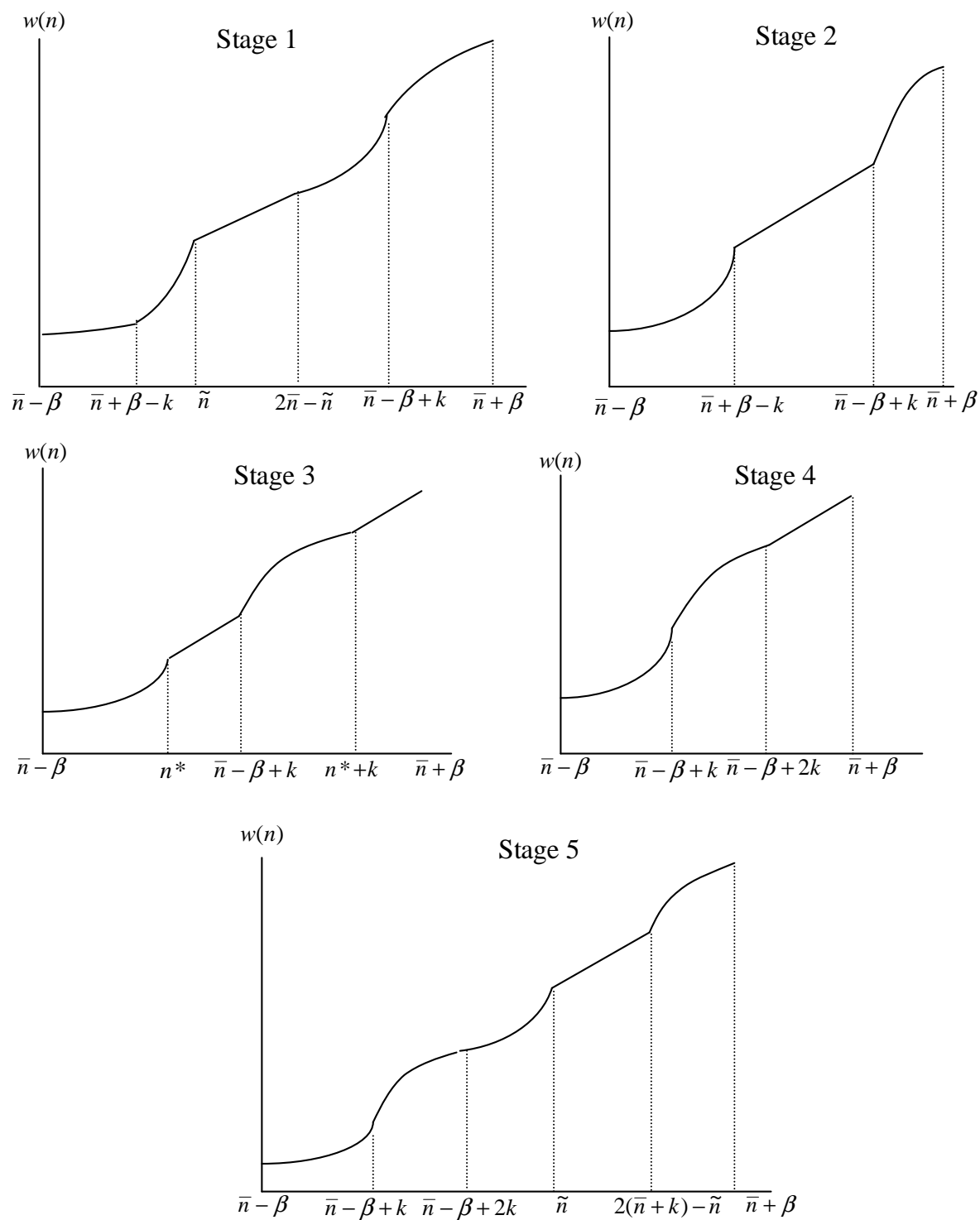

Figure 13: Patterns of Income Distribution

if it binds, there is a major difference in the wage function of talent employed in sector S : it is convex among low-end workers but *concave* among high-end workers. It is because, as talent is increased in either end, the ratio of high to low talent falls since the talent gap is constant. This raises the marginal product of the lower talent but *lowers* that of the higher talent. Algebraically, $dF_A^s(n, n+k)/dn = F_{AA}^s + F_{AB}^s > 0$ while $dF_B^s(n, n+k)/dn = F_{BB}^s + F_{AB}^s < 0$.¹⁹

From talent matching and allocation patterns in various stages it is now straightforward to characterize the shape of the wage function. It is shown in Figure 13. The central feature is that the overall wage function is not convex.

Analytically, it is difficult to go beyond this and determine how an increase in β would affect some index of inequality like the Gini or coefficient of variation. But it is expected that inequality will increase. Together with the inverse-U link between vertical diversity and growth, it also means an inverse-U link between inequality and growth. An increase in inequality will be associated with higher (lower) growth if, originally, inequality is modest (high). This relates to the recent literature on the inequality-growth nexus which finds that there may be a non-monotonic relationship between equity and growth; see, for example, Barro (2000) and Banerjee and Duflo (2003).

6 Concluding Remarks

This paper has analyzed the issue of vertical diversity and growth. Its bench-mark model is a reinterpretation and a simple adaptation of Grossman and Maggi's (2000) model of diversity and trade. It predicts that an increase in diversity increases the long-run growth rate. The main innovation of the paper lies in introducing the concept of communication gap among workers with sufficiently high difference in talents and its bearing towards the effect of diversity on growth. In the presence of such a gap, talent allocation between the consumption-good sector and the R&D sector has a very different – and a changing pattern – as diversity increases. The PPF of the economy has a kink and its nature of shifts due to an increase in diversity depends on the original degree of diversity. The submodular R&D sector employs workers from the low-end of talent distribution but may not match them with workers in the very high-end of the distribution. Hence an increase in vertical diversity in the form of a mean-preserving spread may not be conducive to total production in the R&D sector and therefore may not enhance economic growth.

The degree of diversity in relation to the communication gap matters. As diversity increases within the medium-diversity range, growth rate increases at least over the initial two stages. Within the high-diversity range, it unambiguously falls with diversity in one of the stages and may very well decline with diversity over the last stage. An inverse-U relationship between diversity and growth emerges as the main hypothesis: too little or too much of diversity is not so good for growth.

The analysis of diversity and growth has proven itself to be much more complex in the presence of communication gap compared to that of the baseline model. A number of simplifying assumptions have been used (but hopefully without seriously compromising the core issue of the paper). However, future research must attempt at generalizations. For instance,

¹⁹Given constant returns, we write the TFP-adjusted output as $t_A f(\rho)$ where $\rho = t_B/t_A$ and $f', f'' > 0$. We have $F_A^s = f(\rho) - \rho f'(\rho)$ and $F_B^s = f'(\rho)$. Differentiating these, $F_{AA}^s + F_{AB}^s = \rho f'(\cdot)(t_B - t_A)/t_A^2$ and $F_{BB}^s + F_{AB}^s = -f'(\cdot)(t_B - t_A)/t_A^2$. Given $t_B > t_A$, the former sum is positive, while the latter is negative.

the model assumes a bang-bang cost of communication problems among workers. Instead, one can consider a continuous, convex function of the communication gap: the higher the talent gap, the greater is the marginal loss of output due to communication problems. This is likely to strengthen our main result: the analog of Figure 12 will be a smoother curve with the declining phase of the curve starting early if the convexity of the cost function is high.

If a firm may employ more than two workers, there may be transitive relationship in communicating. If $t_A > t_B > t_C$ and the t_A -worker cannot directly communicate with the t_C -worker, it is still possible that both communicate with the t_B -worker and via the t_B worker they can communicate indirectly. Ceteris paribus, this will weaken the inverse-U hypothesis. However, it is reasonable to postulate that communication is imperfect and as words/communications pass more hands, there is a dilution of the understanding of the original content. This will tend to reinforce our hypothesis.

Considering non-uniform distribution is likely to be quite complex – because it gives rise to the possibility that workers of same talent may not all work in the same sector. Accounting for who works in which sector promises to be much more complicated than what is shown in Figure 6 or Figure 9.

R&D has been assumed to be the main source of growth. However, it can be argued that the right growth strategy may depend on a country's level of development. At relatively low level of development, it may not be realistic to bank on R&D as the main impetus to growth. Probably, imitation and the emphasis on precision is the optimal strategy. Once a country is sufficiently developed, it can focus on R&D. The rationality behind such a sequence of strategy needs scrutiny.

There are of course standard growth-theoretic features, the implications of which need to be examined – such as capital accumulation, private holding of blue prints as assets (*a la* Romer) and endogenous saving rate via either an infinite-horizon or an over-lapping generations household framework.

Finally, from policy perspective, it will be most interesting to endogeneize education policy. But, all said, it is hoped that the analysis has offered some meaningful understanding of the relationship between vertical diversity and growth.

Appendix 1

We prove here that in the basic model, $d\tilde{n}/d\gamma < 0$. Considering (6'), we first determine how its r.h.s. changes as γ increases. The proportional changes with respect to an increase in γ in the numerator and the denominators are respectively

$$\frac{(F_B^s - F_A^s)(\bar{n} - \tilde{n})}{F^s[\bar{n} - \gamma(\bar{n} - \tilde{n}), \bar{n} + \gamma(\bar{n} - \tilde{n})]} \equiv \xi_1; \quad \frac{\int_{n_0}^{\tilde{n}} (F_B^s - F_A^s)(\bar{n} - \tilde{n})\phi(n)dn}{\int_{n_0}^{\tilde{n}} F^s[\gamma(n - \bar{n}) + \bar{n}, 2\bar{n} - \gamma(n - \bar{n}) - \bar{n}]\phi(n)dn} \equiv \xi_2.$$

We have $\tilde{n} < \bar{n}$, and, since the second argument of F^s is greater than the first, $F_B^s - F_A^s > 0$. Thus both ξ_1 and ξ_2 are positive. Next, we prove that the function

$$h(n) \equiv \frac{(F_B^s - F_A^s)(\bar{n} - n)}{F^s(\cdot)}$$

decreases with n for any $n \leq \tilde{n}$. Totally differentiating it and using $F^s = [\bar{n} + \gamma(n - \bar{n})]F_A^s + [\bar{n} - \gamma(n - \bar{n})]F_B^s$,

$$\begin{aligned} h'(n) &= \frac{-F^s(\cdot)(F_B^s - F_A^s) + \gamma(\bar{n} - n)F^s(\cdot)(2F_{AB}^s - F_{AA}^s - F_{BB}^s) + \gamma(\bar{n} - n)(F_B^s - F_A^s)^2}{[F^s(\cdot)]^2} \\ &= -\frac{\gamma(\bar{n} - n)F^s(\cdot)(F_{AA}^s + F_{BB}^s - 2F_{AB}^s) + (F_B^s - F_A^s)[F^s - \gamma(\bar{n} - n)(F_B^s - F_A^s)]}{[F^s(\cdot)]^2} \\ &= -\frac{\gamma(\bar{n} - n)F^s(\cdot)(F_{AA}^s + F_{AA}^s - 2F_{AB}^s) + \bar{n}(F_B^s - F_A^s)(F_A^s + F_B^s)}{[F^s(\cdot)]^2} < 0, \end{aligned}$$

since $F_B^s > F_A^s > 0$, F_{AA}^s , $F_{BB}^s > 0$ and $F_{AB} < 0$. This implies that for any $n < \tilde{n}$,

$$\begin{aligned} \frac{(F_B^s - F_A^s)(\bar{n} - \tilde{n})}{F^s(\cdot)} &< \frac{(F_B^s - F_A^s)(\bar{n} - n)}{F^s(\cdot)} = \frac{(F_B^s - F_A^s)(\bar{n} - n)\phi(n)}{F^s(\cdot)\phi(n)} \\ \Rightarrow \frac{(F_B^s - F_A^s)(\bar{n} - \tilde{n})}{F^s(\cdot)} &< \frac{\int_{n_0}^{\tilde{n}} (F_B^s - F_A^s)(\bar{n} - n)\phi(n)dn}{\int_{n_0}^{\tilde{n}} F^s(\cdot)\phi(n)dn}, \text{ i.e., } \xi_1 < \xi_2. \end{aligned}$$

Given this it immediately following from (6') that $d\tilde{n}/d\gamma < 0$.

Appendix 2

It is shown here that in the case of medium diversity, the PPF shifts to the right on the G^s -axis. In view of (10), the intercept on the G^s axis is given by

$$\bar{G}^s = \frac{1}{2\beta} \left[\int_{\bar{n}-\beta}^{\bar{n}+\beta-k} F^s(n, n+k)dn + \int_{\bar{n}+\beta-k}^{\bar{n}} F^s(n, 2\bar{n}-n)dn \right].$$

Totally differentiating it with respect to β , $2\beta^2 \frac{d\bar{G}^s}{d\beta} = A_1$, where

$$\begin{aligned} A_1 &\equiv \beta[F^s(\bar{n} + \beta - k, \bar{n} + \beta) + F^s(\bar{n} - \beta, \bar{n} - \beta + k) - F^s(\bar{n} + \beta - k, \bar{n} - \beta + k)] \\ &\quad - \int_{\bar{n}-\beta}^{\bar{n}+\beta-k} F^s(n, n+k)dn - \int_{\bar{n}+\beta-k}^{\bar{n}} F^s(n, 2\bar{n}-n)dn. \end{aligned} \quad (A1)$$

At $\beta = k/2$, this reduces to

$$\begin{aligned} & \frac{k}{2} F^s \left(\bar{n} - \frac{k}{2}, \bar{n} + \frac{k}{2} \right) - \int_{\bar{n}-k/2}^{\bar{n}} F^s(n, 2\bar{n} - n) dn \\ & > \frac{k}{2} F^s \left(\bar{n} - \frac{k}{2}, \bar{n} + \frac{k}{2} \right) - \int_{\bar{n}-k/2}^{\bar{n}} F^s(\bar{n} - k/2, \bar{n} + k/2) dn, \\ & \text{since } F^s(n, 2\bar{n} - n) < F^s(\bar{n} - k/2, \bar{n} + k/2) \text{ for } n \in (\bar{n} - k/2, \bar{n}) \\ & = \frac{k}{2} F^s \left(\bar{n} - \frac{k}{2}, \bar{n} + \frac{k}{2} \right) - \frac{k}{2} F^s \left(\bar{n} - \frac{k}{2}, \bar{n} + \frac{k}{2} \right) = 0, \end{aligned}$$

i.e. $A_1 > 0$ at $\beta = k/2$. Next,

$$\begin{aligned} \frac{1}{\beta} \frac{dA_1}{d\beta} &= [\{F_A^s(\cdot) + F_B^s(\cdot)\}_{(\bar{n}+\beta-k, \bar{n}+\beta)} - \{F_A^s(\cdot) + F_B^s(\cdot)\}_{(\bar{n}-\beta, \bar{n}-\beta+k)}] \\ &+ [\{F_B^s(\cdot) - F_A^s(\cdot)\}_{(\bar{n}+\beta-k, \bar{n}-\beta+k)}]. \end{aligned}$$

The marginal products are functions of the ratio of the arguments and we have $(\bar{n} + \beta)/(\bar{n} + \beta - k) < (\bar{n} - \beta + k)/(\bar{n} - \beta)$. Hence property (d) of the production function listed in the text implies that the term inside the former pair square brackets is positive. By property (c), the term in the latter pair square brackets is positive also. Thus, A_1 is increasing in β . Together with $A_1 > 0$ at $\beta = k/2$, it implies that $A_1 > 0$, i.e., $dG^s/d\beta > 0$.

Appendix 3

We prove that in the case of medium diversity, $dG^s/d\beta > 0$ in the partially binding region (stage 1). Totally differentiating the expression of G^s in (10),

$$dG^s - \frac{F^s(\tilde{n}, 2\bar{n} - \tilde{n})}{2\beta} d\tilde{n} = \frac{A_2}{2\beta^2} d\beta, \text{ where} \quad (\text{A2})$$

$$\begin{aligned} A_2 \equiv & \beta[F^s(\bar{n} + \beta - k, \bar{n} + \beta) + F^s(\bar{n} - \beta, \bar{n} - \beta + k) - F^s(\bar{n} + \beta - k, \bar{n} - \beta + k)] \\ & - \int_{\bar{n}-\beta}^{\bar{n}+\beta-k} F^s(n, n+k) dn - \int_{\bar{n}+\beta-k}^{\bar{n}} F^s(n, 2\bar{n} - n) dn. \end{aligned} \quad (\text{A3})$$

Observe that $A_2 > A_1$, where A_1 is defined in Appendix 2. Since $A_1 > 0$, we have $A_2 > 0$. Next, express (12) as

$$\begin{aligned} G^s &= \frac{\Lambda}{2\beta} (\bar{n} - \tilde{n}) F^s(\tilde{n}, 2\bar{n} - \tilde{n}), \text{ implying} \\ dG^s + \frac{\Lambda A_3}{2\beta} d\tilde{n} &= \frac{\Lambda A_4}{2\beta^2} d\beta, \text{ where} \quad (\text{A4}) \\ A_3 \equiv & F^s(\tilde{n}, 2\bar{n} - \tilde{n}) + (\bar{n} - \tilde{n}) [F_B^s(\tilde{n}, 2\bar{n} - \tilde{n}) - F_B^s(\tilde{n}, 2\bar{n} - \tilde{n})] \\ A_4 \equiv & -(\bar{n} - \tilde{n}) F^s(\tilde{n}, 2\bar{n} - \tilde{n}). \end{aligned}$$

Solving (A2) and (A4),

$$\frac{dG^s}{d\beta} = \frac{\Lambda}{4\beta^3 \Delta} \begin{vmatrix} A_2 & -F^s(\tilde{n}, 2\bar{n} - \tilde{n}) \\ A_4 & A_3 \end{vmatrix} \text{ where } \Delta > 0 \text{ is the determinant of the system.}$$

Substituting A_3 and A_4 into the above and noting that the term $(\bar{n} - \tilde{n})[F_B^s(\cdot) - F_A^s(\cdot)]|_{(\tilde{n}, 2\bar{n} - \tilde{n})}$ in A_3 is positive,

$$\frac{dG^s}{d\beta} > \frac{\Lambda F^s(\tilde{n}, 2\bar{n} - \tilde{n})}{4\beta^3 \Delta} [A_2 - (\bar{n} - \tilde{n})F^s(\tilde{n}, 2\bar{n} - \tilde{n})] \equiv \frac{\Lambda F^s(\tilde{n}, 2\bar{n} - \tilde{n})}{4\beta^3 \Delta} A_5(\tilde{n}).$$

It is sufficient to show that $A_5(\tilde{n}) > 0$. First check that $dA_5/d\tilde{n} > 0$. Since $\tilde{n} > \bar{n} + \beta - k$, it follows that $A_5(\cdot) > A_5(\bar{n} + \beta - k)$. It is then sufficient to prove that

$$A_5(\bar{n} + \beta - k) = \beta[F^s(\bar{n} + \beta - k, \bar{n} + \beta) + F^s(\bar{n} - \beta, \bar{n} - \beta + k)] - \int_{\bar{n} - \beta}^{\bar{n} + \beta - k} F^s(n, n + k)dn - kF^s(\bar{n} + \beta - k, \bar{n} - \beta + k) > 0.$$

Treat $A_5(\bar{n} + \beta - k)$ as $A_6(\beta)$. We have $A_6(k/2) = 0$ and

$$A_6'(\beta) = \beta[F_A^s(\cdot) + F_B^s(\cdot)]|_{(\bar{n} + \beta - k, \bar{n} + \beta)} - [F_A^s(\cdot) + F_B^s(\cdot)]|_{(\bar{n} - \beta, \bar{n} - \beta + k)} + k[F_B^s(\cdot) - F_A^s(\cdot)]|_{(\bar{n} + \beta - k, \bar{n} - \beta + k)} > 0.$$

It is already proved in Appendix 2 that the coefficients of β and k are positive. This proves $A_6(\beta) = A_5(\tilde{n}) > 0$ and thus $dG^s/d\beta > 0$.

Appendix 4

It refers to the medium-diversity case. Eqs. (17) and (18) are derived. Consider Figure 14(a). It depicts the market-clearing condition (12) in the partially binding region. The l.h.s. and the r.h.s. of this equation (as functions of \tilde{n}) are respectively represented by the upward sloping curve and the downward sloping curve. The solution of \tilde{n} equal to $\bar{n} + \beta - k$ defines β_1 . This holds when the vertical intercepts of the two curves at $\bar{n} + \beta - k$ coincide. This gives rise to eq. (17).

Similarly, Figure 14(b) shows the market-clearing condition (16) in the overly binding region. The upward and the downward sloping curves as functions of n^* represent respectively the l.h.s. and the r.h.s. of this equation. The solution of n^* equal to $\bar{n} + \beta - k$ defines β_2 . This happens when the vertical intercepts of the two curves at $n^* = \bar{n} + \beta - k$ match. This yields eq. (18).

Note that the r.h.s. of the eqs. (17) and (18) have the same expression and it is declining in β . Thus $\beta_1 < \beta_2$ if the l.h.s. of (17) exceeds that of (18) at any β . This is indeed equivalent to $p_s^p|_{\tilde{n}=\tilde{n}} > p_s^o|_{n^*=\tilde{n}}$, proved already in footnote 8.

Appendix 5

Lemma 3 is proved here. Define $n_0 \equiv \bar{n} - \beta$, $n_1 \equiv \bar{n} + \beta$. Turn now to Figure 15, in which workers in a middle range, $b - 2k$ to b are constrained by C.G. and the rest are not. Accordingly, the total output in sector S is given by $2\beta\mathcal{Z}$, where

$$\mathcal{Z}(b) \equiv \int_{n_0}^{\frac{n_0 + b - 2k}{2}} F^s(n, n_0 + b - 2k - n)dn + \int_{b - 2k}^{b - k} F^s(n, n + k)dn + \int_b^{\frac{b + n_1}{2}} F^s(n, n_1 + b - n)dn. \quad (\text{A5})$$

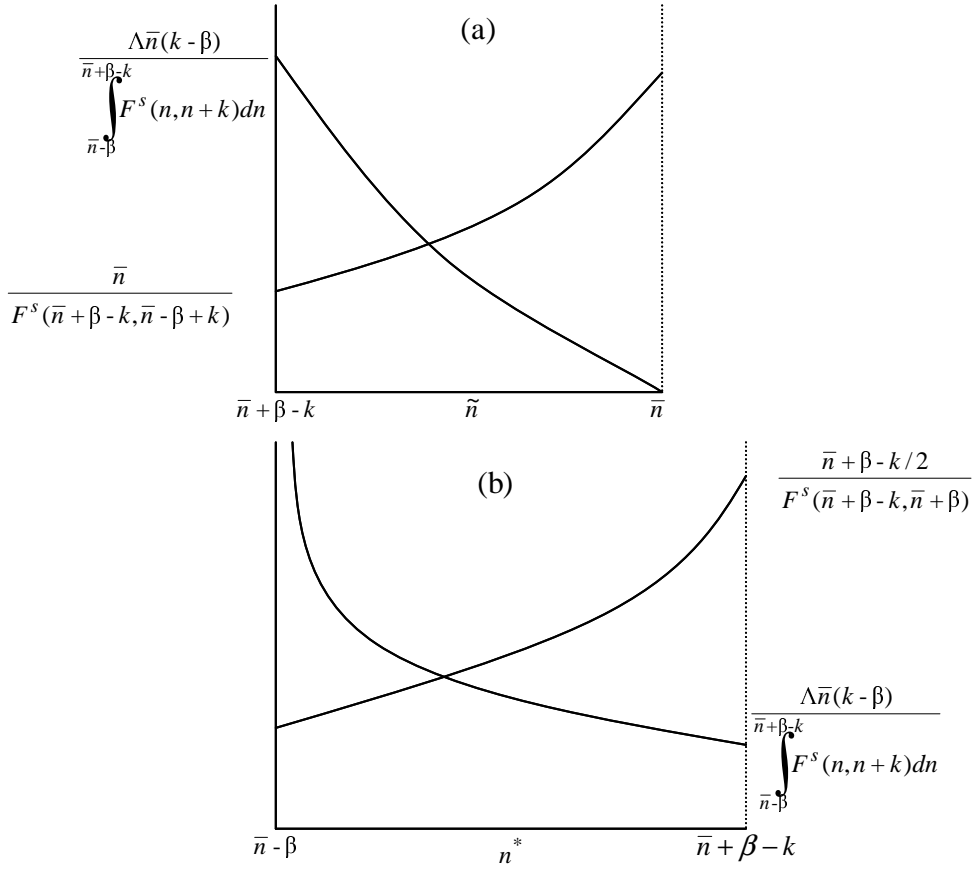
Figure 14: Solution of \tilde{n} and n^* in the Medium Diversity Case

Note that b can vary from $n_0 + 2k$ to n_1 . First, we show that $\mathcal{Z}(b)$ is a convex function, i.e., $\frac{d^2 \mathcal{Z}}{db^2} > 0$. We have

$$\begin{aligned}
\frac{d\mathcal{Z}}{db} &= \frac{1}{2} F^s \left(\frac{n_0 + b - 2k}{2}, \frac{n_0 + b - 2k}{2} \right) + \int_{n_0}^{\frac{n_0 + b - 2k}{2}} F_B^s(n, n_0 + b - 2k - n) dn \\
&\quad + F^s(b - k, b) - F^s(b - 2k, b - k) \\
&\quad + \frac{1}{2} F^s \left(\frac{b + n_1}{2}, \frac{b + n_1}{2} \right) - F(b, n_1) + \int_b^{\frac{b + n_1}{2}} F_B^s(n, n_1 + b - n) dn.
\end{aligned} \tag{A6}$$

$\frac{1}{2\beta}$	C.G. Not binding	C.G. Binding Talent n works with Talent $n+k$	C.G. Not binding
n_0	$b - 2k$	b	n_1

Figure 15: High Diversity: Talent Allocation if all Talents are used in Sector S

Totally differentiating (A6),

$$\begin{aligned} \frac{d^2 \mathcal{Z}}{db^2} &= \left[\int_{n_0}^{\frac{n_0+b-2k}{2}} F_{BB}^s(n, n_0 + b - 2k - n) dn + \int_b^{\frac{b+n_1}{2}} F_{BB}^s(n, n_1 + b - n) dn \right] \\ &+ \left[\left\{ \frac{F_A^s + F_B^s}{4} + \frac{F_B^s}{2} \right\} \Big|_{\left(\frac{n_0+b-2k}{2}, \frac{n_0+b-2k}{2}\right)} + \left\{ \frac{F_A^s + F_B^s}{4} + \frac{F_B^s}{2} \right\} \Big|_{\left(\frac{b+n_1}{2}, \frac{b+n_1}{2}\right)} \right. \\ &- \left. \{F_A^s(\cdot) + F_B^s(\cdot)\} \Big|_{(b, n_1)} \right] \\ &+ \left[\{F_A^s(\cdot) + F_B^s(\cdot)\} \Big|_{(b-k, b)} - \{F_A^s(\cdot) + F_B^s(\cdot)\} \Big|_{(b-2k, b-k)} \right]. \end{aligned}$$

The term inside the first pair of square brackets is obviously positive. When $t_A = t_B = t$, F_A^s and F_B^s are equal and independent of t as $t_B/t_A = 1$. Utilizing this, the terms inside the second pair of square brackets reduce to $\chi = (F_A^s + F_B^s)|_{(t, t)} - \{F_A^s(\cdot) + F_B^s(\cdot)\}|_{(b, n_1)}$ for any $t > 1$. By property (d) of the submodular production function, $\chi > 0$. Hence the term inside the second pair of square brackets is positive. By the same property, the term inside the last pair of the square brackets is positive also. This completes the proof that $d^2 \mathcal{Z}/db^2 \geq 0$.

Given that \mathcal{Z} is convex, it attains maximum when b takes an extremal value. The upper and lower bound of b are $n_0 + 2k$ and n_1 .²⁰ Now, using $n_0 = \bar{n} - \beta$, $n_1 = \bar{n} + \beta$ and for notational simplicity, choosing $\bar{n} = 1$, we have, from (A5),

$$\begin{aligned} \mathcal{A} &\equiv \mathcal{Z}|_{b=n_0+2k} = \int_{1-\beta}^{1-\beta+k} F^s(n, n+k) dn + \int_{1-\beta+2k}^{1+k} F^s(n, 2+2k-n) dn \\ \mathcal{B} &\equiv \mathcal{Z}|_{b=n_1} = \int_{1-\beta}^{1-k} F^s(n, 2-2k-n) dn + \int_{1+\beta-2k}^{1+\beta-k} F^s(n, n+k) dn \end{aligned} \quad (\text{A7})$$

We show that $\mathcal{A} > \mathcal{B}$, which will prove Lemma 3.

Check that when $\beta = k$, $\mathcal{A} - \mathcal{B} = 0$. Since $\beta \in [k, 1]$, it is then sufficient to prove that $d(\mathcal{A} - \mathcal{B})/d\beta > 0$. From (A7),

$$\begin{aligned} \frac{d(\mathcal{A} - \mathcal{B})}{d\beta} &= -F^s(1 - \beta + k, 1 - \beta + 2k) + F^s(1 - \beta, 1 - \beta + k) \\ &+ F^s(1 - \beta + 2k, 1 + \beta) - F^s(1 + \beta - k, 1 + \beta) \\ &+ F^s(1 + \beta - 2k, 1 + \beta - k) - F^s(1 - \beta, 1 + \beta - 2k) \end{aligned} \quad (\text{A8})$$

State (A8) as

$$\begin{aligned} \psi(\alpha) &\equiv F^s(1 - \beta, y + \alpha) - F^s(1 - \beta, y) + F^s(x + \alpha, 1 + \beta) - F^s(x, 1 + \beta) + F^s(x, y) \\ &- F^s(x + \alpha, y + \alpha), \text{ where } x \equiv 1 + \beta - k, y \equiv 1 + \beta - 2k, \alpha \equiv 3k - 2\beta. \end{aligned} \quad (\text{A9})$$

Given that $k \in [2/3, 1)$ and $\beta \in [k, 1]$, $\alpha > 0$. Also note that $\psi(0) = 0$. It is then sufficient to prove that $\psi'(\alpha) > 0 \forall \alpha > 0$. We have

$$\psi'(\alpha) = F_B^s(1 - \beta, y + \alpha) + F_A^s(x + \alpha, 1 + \beta) - [F_A^s(\cdot) + F_B^s(\cdot)]|_{(x+\alpha, y+\alpha)}. \quad (\text{A10})$$

²⁰In the extreme submodularity case, there $F^s(t_A, t_B) = \text{Max}(t_A, t_B)$ and $b = n_0 + 2k$ or n_1 yields the same value of \mathcal{Z} , equal to

$$k^2 - \frac{k(n_1 - n_0)}{2} - \frac{n_0^2}{8} + \frac{3n_1^2}{8} - \frac{n_0 n_1}{4}.$$

The relevant situation is where the lower talent has some contribution towards production.

Define

$$\rho_1 \equiv \frac{y + \alpha}{1 - \beta} > 1; \rho_2 \equiv \frac{y + \alpha}{x + \alpha} > 1; \rho_3 \equiv \frac{1 + \beta}{x + \alpha} > 1.$$

We can state (A10) as $\psi'(\alpha) = F_A^s(\rho_3) - F_A^s(\rho_2) + F_B^s(\rho_1) - F_B^s(\rho_2)$. Verify that $\rho_1 > \rho_2 > \rho_3$. Property (c) of the submodular production function implies $\psi'(\alpha) > 0$. ■

Appendix 6

We show that in case of high-diversity, $p_s^p > p_s^o$ at the just-fully-binding point. We substitute $\bar{n} - \beta + 2k$ for \bar{n} and $\bar{n} - \beta + k$ for n^* . Then $p_s^p < p_s^o$ is equivalent to

$$\begin{aligned} \frac{\bar{n} + k}{F^s(\bar{n} - \beta + 2k, \bar{n} + \beta)} &> \frac{\bar{n} - \beta + 3k/2}{F^s(\bar{n} - \beta + k, \bar{n} - \beta + 2k)} \\ \Leftrightarrow \frac{F^s(\bar{n} - \beta + 2k, \bar{n} + \beta)}{\bar{n} + k} &< \frac{F^s(\bar{n} - \beta + k, \bar{n} - \beta + 2k)}{\bar{n} - \beta + 3k/2}. \end{aligned}$$

The last inequality can be written in the form of

$$\frac{F^s(x_1, y_1)}{x_1 + y_1} < \frac{F^s(x_2, y_2)}{x_2 + y_2}, \text{ where } x_1 \equiv \bar{n} - \beta + 2k > x_2 \equiv \bar{n} - \beta + k, y_1 \equiv \bar{n} + \beta > y_2 \equiv \bar{n} - \beta + 2k.$$

Note that $|y_1 - y_2| < |x_1 - x_2|$. Hence it is sufficient to prove that $dF^s(x, y)/(x + y) > 0$, where $x < y$ and $dx < dy < 0$. The last two inequalities imply $xdy - ydx > 0$. Now, on differentiation,

$$d \left[\frac{F^s(x, y)}{x + y} \right] = \frac{(F_B^s - F_A^s)(xdy - ydx)}{(x + y)^2} > 0.$$

Appendix 7

Here we prove that in the high-diversity case, the PPF may shift inside on the G^s -axis. From (19), if all workers are in sector S the output of this sector is given by

$$\bar{G}^s = \frac{1}{2\beta} \left[\int_{\bar{n}-\beta}^{\bar{n}-\beta+k} F^s(n, n+k) dn + \int_{\bar{n}-\beta+2k}^{\bar{n}+k} F^s(n, 2\bar{n} + 2k - n) dn \right].$$

Totally differentiating it with respect to β ,

$$\begin{aligned} 2\beta^2 \frac{d\bar{G}^s}{d\beta} &= \beta [-F^s(\bar{n} - \beta + k, \bar{n} - \beta + 2k) + F^s(\bar{n} - \beta, \bar{n} - \beta + k) + F^s(\bar{n} - \beta + 2k, \bar{n} + \beta)] \\ &\quad - \left[\int_{\bar{n}-\beta}^{\bar{n}-\beta+k} F^s(n, n+k) dn + \int_{\bar{n}-\beta+2k}^{\bar{n}+k} F^s(n, 2\bar{n} + 2k - n) dn \right] \end{aligned} \quad (\text{A11})$$

Evaluated at $\beta = \bar{n}$, and normalizing $\bar{n} = 1$ (for no loss of generality), the r.h.s. of (A11) is equal to

$$-kF^s(1, 2) + F^s(0, k) + 2F^s(k, 1) - \int_0^k F^s(n, n+k) dn - \int_{2k}^{1+k} F^s(n, 2 + 2k - n) dn \geq 0.$$

As an example, let $F^s(\cdot)$ be the submodular function in (1). Then the above expression is equal to

$$-k(1+2^\theta)^{1/\theta} + k + 2(k^\theta + 1)^{1/\theta} - \int_0^k [n^\theta + (n+k)^\theta]^{1/\theta} - \int_{2k}^{1+k} [n^\theta + (2+2k-n)^\theta]^{1/\theta}.$$

As $k \rightarrow \bar{n} = 1$ and $\theta \rightarrow \infty$, it reduces to $-2 + 1 + 2 - \int_0^1 (n+1)^{1/\theta} dn = -0.5$. This means that if k and θ are high enough, \bar{G}^s falls with β in the neighborhood of $\beta = \bar{n}$. Indeed, simulations show that $d\bar{G}/d\beta < 0$ holds as long as $k \geq .75$ and $\theta \geq 2.4$.

Appendix 8

We write the market-clearing condition (21) as

$$\beta G^s = \frac{\Lambda}{2} (\bar{n} + k - \tilde{n}) F^s(\tilde{n}, 2\bar{n} + 2k - \tilde{n}). \quad (\text{A12})$$

Regard this equation together with the expression of G^s in (19) as having two variables: G^s and \tilde{n} . Taking the comparative statics of this system with respect to β ,

$$\frac{2\Delta_1}{\Lambda} \frac{dG^s}{d\beta} = \begin{vmatrix} a_1 & a_2 \\ a_3 & a_4 \end{vmatrix}, \quad (\text{A13})$$

where, Δ_1 , the Jacobian of the system, is positive and

$$\begin{aligned} a_1(\tilde{n}) &= -\frac{1}{\beta} \left[\int_{\bar{n}-\beta}^{\bar{n}-\beta+k} F^s(n, n+k) dn + \int_{\bar{n}-\beta+2k}^{\bar{n}} F^s(n, 2\bar{n} + 2k - n) dn \right] \\ &\quad + F^s(\bar{n} - \beta + 2k, \bar{n} + \beta) + F^s(\bar{n} - \beta, \bar{n} - \beta + k) - F^s(\bar{n} - \beta + k, \bar{n} - \beta + 2k) \geq 0 \end{aligned} \quad (\text{A14})$$

$$a_2(\tilde{n}) = -F^s(\tilde{n}, 2\bar{n} + 2k - \tilde{n}) < 0$$

$$a_3(\tilde{n}) = -\frac{1}{\beta} (\bar{n} + k - \tilde{n}) F^s(\tilde{n}, 2\bar{n} + 2k - \tilde{n}) < 0$$

$$a_4(\tilde{n}) = (\bar{n} + k - \tilde{n}) [F_B^s(\cdot) - F_A^s(\cdot)]|_{(\bar{n}, 2\bar{n} + 2k - \tilde{n})} + F^s(\tilde{n}, 2\bar{n} + 2k - \tilde{n}) > 0.$$

It is easy to derive that the r.h.s. of (A13) is increasing in \tilde{n} . In the partially binding region, $\tilde{n} \leq \bar{n} + k$. Thus the above determinant is less than

$$\begin{vmatrix} a_1 & a_2 \\ a_3 & a_4 \end{vmatrix}_{\tilde{n}=\bar{n}+k} = a_1 a_4,$$

since, at $\tilde{n} = \bar{n} + k$, $a_3 = 0$. Given that $a_4 > 0$, $dG^s/d\beta < 0$ if $a_1(\bar{n} + k) < 0$. From (A14),

$$\begin{aligned} a_1(\bar{n} + k) &= -\frac{1}{\beta} \left[\int_{\bar{n}-\beta}^{\bar{n}-\beta+k} F^s(n, n+k) dn + \int_{\bar{n}-\beta+2k}^{\bar{n}+k} F^s(n, 2\bar{n} + 2k - n) dn \right] \\ &\quad + F^s(\bar{n} - \beta + 2k, \bar{n} + \beta) + F^s(\bar{n} - \beta, \bar{n} - \beta + k) - F^s(\bar{n} - \beta + k, \bar{n} - \beta + 2k). \end{aligned}$$

Note that this is exactly same as the r.h.s. of (A11), the sign of which determines that of $d\bar{G}^s/d\beta$. Thus if the PPF shrinks in on the G^s -axis, $dG^s/d\beta < 0$ in stage 5.

References

- Banerjee, A. and E. Duflo, "inequality and Growth: What Can the Data Say?," *Journal of Economic Growth*, 8, 2003, 267-299.
- Barro, R., "Government Spending in a Simple Model of Endogenous Growth," *Journal of Political Economy*, 98 Part 2, 1990, S103-26.
- Barro, R., "Inequality and Growth in a Panel of Countries," *Journal of Economic Growth*, 5, 2000, 5-32.
- Basu, Kaushik, *Analytical Development Economics: The Less Developed Economy Revisited*, MIT Press, 1997.
- Easterly, W. and R. Levine, "Africa's Growth Tragedy: Policies and Ethnic Division," *Quarterly Journal of Economics*, 112 (4), 1997, 1203-1250.
- Florida, R., "The Economic Geography of Talent," *Annals of the Association of American Geographers*, 92(4), 2002, 743-755.
- Florida, R., *The Rise of the Creative Class: And How It's Transforming Work, Leisure, Community and Everyday Life*, Basic Books, 2004.
- Grossman, G. M. and G. Maggi, "Diversity and Trade," *American Economic Review* 90 (5), December 2000, 1255-1275.
- Kremer, M., "The O-Ring Theory of Economic Development," *Quarterly Journal of Economics*, 108 (3), 1993, 551-75.
- Milgrom, P. and J. Roberts, "The Economics of Modern Manufacturing: Technology, Strategy and Organization," *American Economic Review*, 80 (3), 1990, 511-528.
- Murphy, K., A. Shleifer and R. W. Vishny, "The Allocation of Talent: Implications for Growth," *Quarterly Journal of Economics*, 106, 1991, 503-530.
- Nipon Keidanren (Japan Business Federation), *Japan 2025: Envisioning a Vibrant, Attractive Nation in the Twenty-First Century*, 2003, Keizai Koho Center (Japan Institute for Social and Economic Affairs), Tokyo.
- OECD Statistics of Canada, *Literacy in the Information Age: Final Report of the International Adult Literacy Survey*, 2000.
- Romer, P., "Endogenous Technological Change," *Journal of Political Economy*, 98, 1990, S71-S102.
- Zak, P. and S. Knack, "Trust and Growth," *Economic Journal*, 111, April 2001, 295-321.